







Führungs- und Laufschienen Silent Aluflex 40
Silent Aluflex 40 Guide and running tracks
Rails de guidage et de roulement Silent Aluflex 40
Carriles guía y carriles de deslizamiento Silent Aluflex 40

gilt für Artikel:
 applies to Cat. No.:
 valable pour référence :
 adecuado para N° de ref.:
 403.36.xxx
 403.64.xxx
 403.5x.xxx



	Vorfront - Montage Führungs- und Laufschienen 2
	Vorfront - Guide and running track installation
	Vorfront - Montage de rails de guidage et de roulement
	Vorfront - Montaje de carriles guía y carriles de deslizamiento
	Infront - Montage Führungs- und Laufschienen 6
	Infront - Guide and running track installation
	Infront - Montage de rails de guidage et de roulement
	Infront - Montaje de carriles guía y carriles de deslizamiento
	Schrägtürführung - Montage Führungs- und Laufschienen 9
	Angled door guidance - Guide and running track installation
	Guidage de porte avec inclinaison - Montage de rails de guidage et de roulement
	Guía para puerta oblicua - Montaje de carriles guía y carriles de deslizamiento
	Tür ein/aushängen 12
	Installing/removing door
	Accrocher/décrocher la porte
	Colgar / Descolgar la puerta
	Einstellung 14
	Adjustment
	Réglage
	Ajuste
	Zubehör 15
	Accessories
	Accessoires
	Accesorios

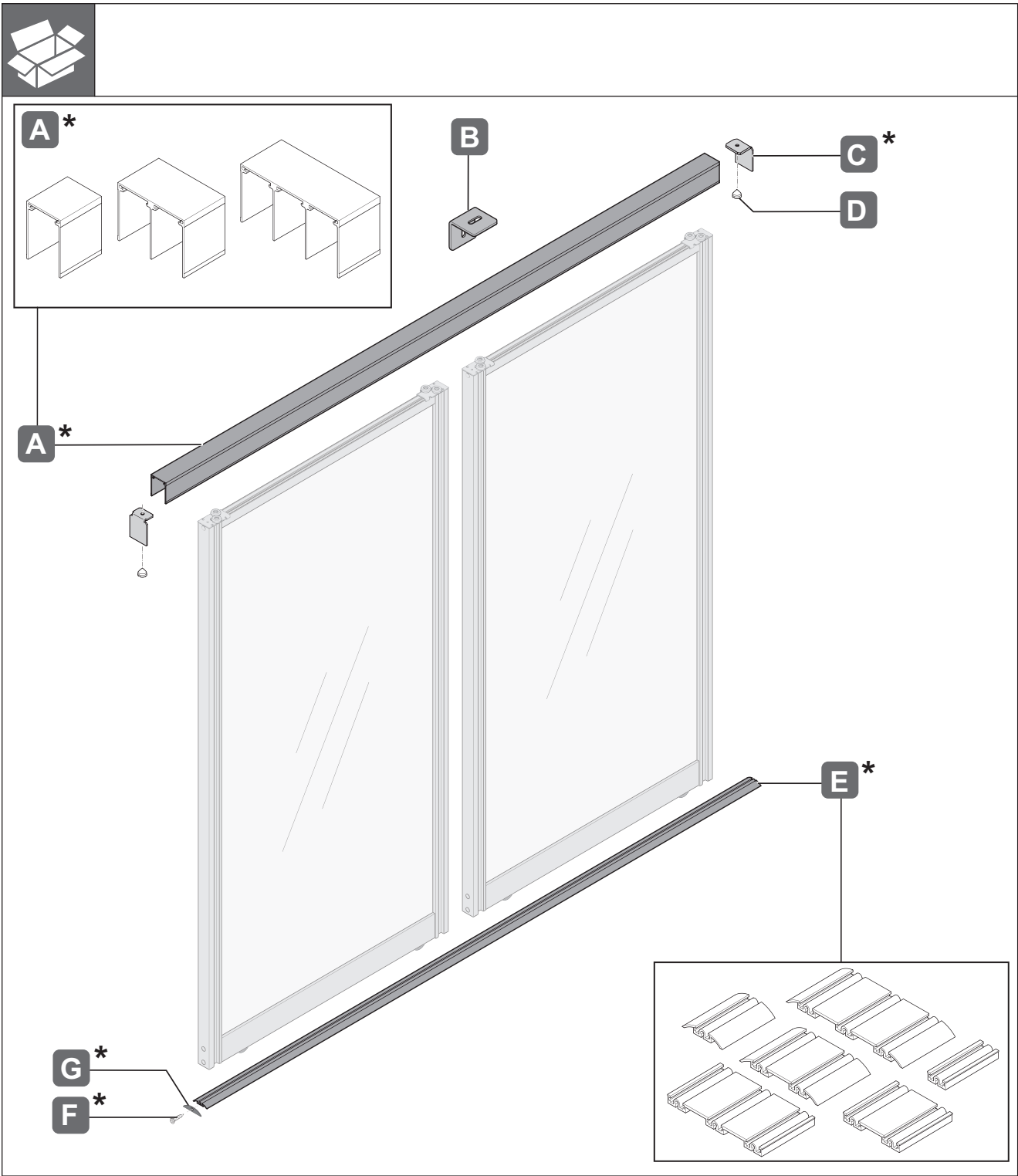

*Ausführung vom Bestellumfang abhängig
 * Version depend on the order
 * Version en fonction de l'étendue de la commande
 * Versión en función del pedido

H 09/08 Maße in mm – Dimensions in mm – Medidas en mm



Vorfront - Montage Führungs- und Laufschienen
Vorfront - Guide and running track installation
Vorfront - Montage de rails de guidage et de roulement
Vorfront - Montaje de carriles guía y carriles de deslizamiento

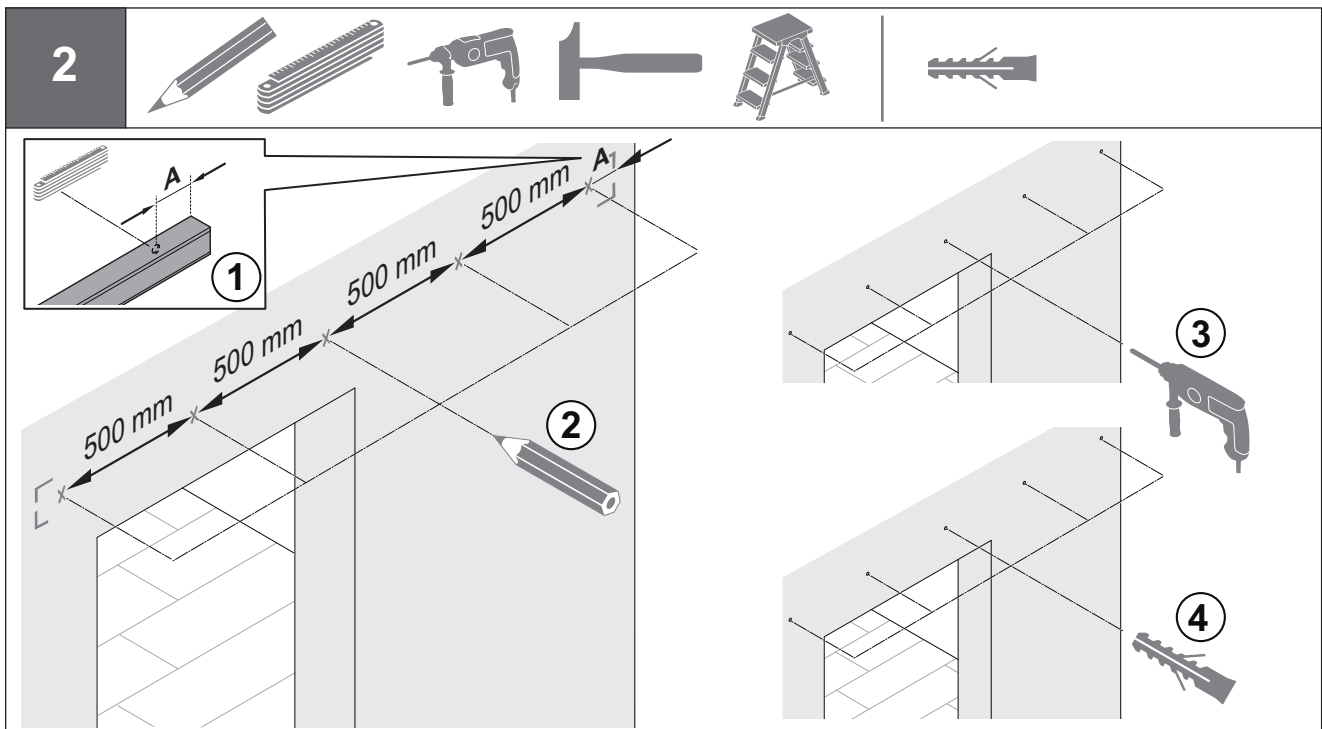
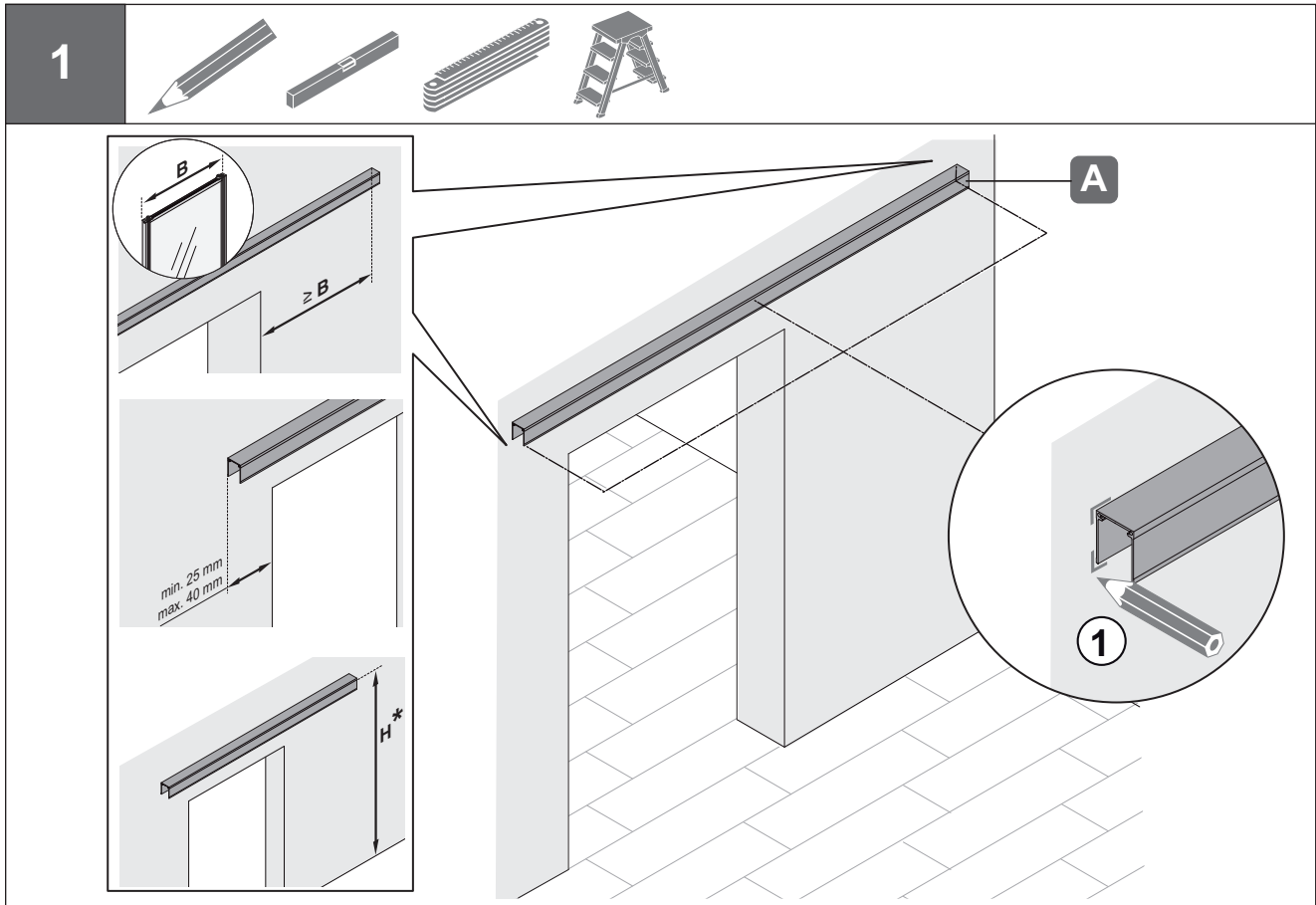

- *Montagehöhe H ist abhängig von Bestellmaßen
- * Installation height H depends on the ordered door dimensions
- * La hauteur de montage H est dépendante des dimensions commandées
- * La altura de montaje H depende de las medidas indicadas en el pedido

3

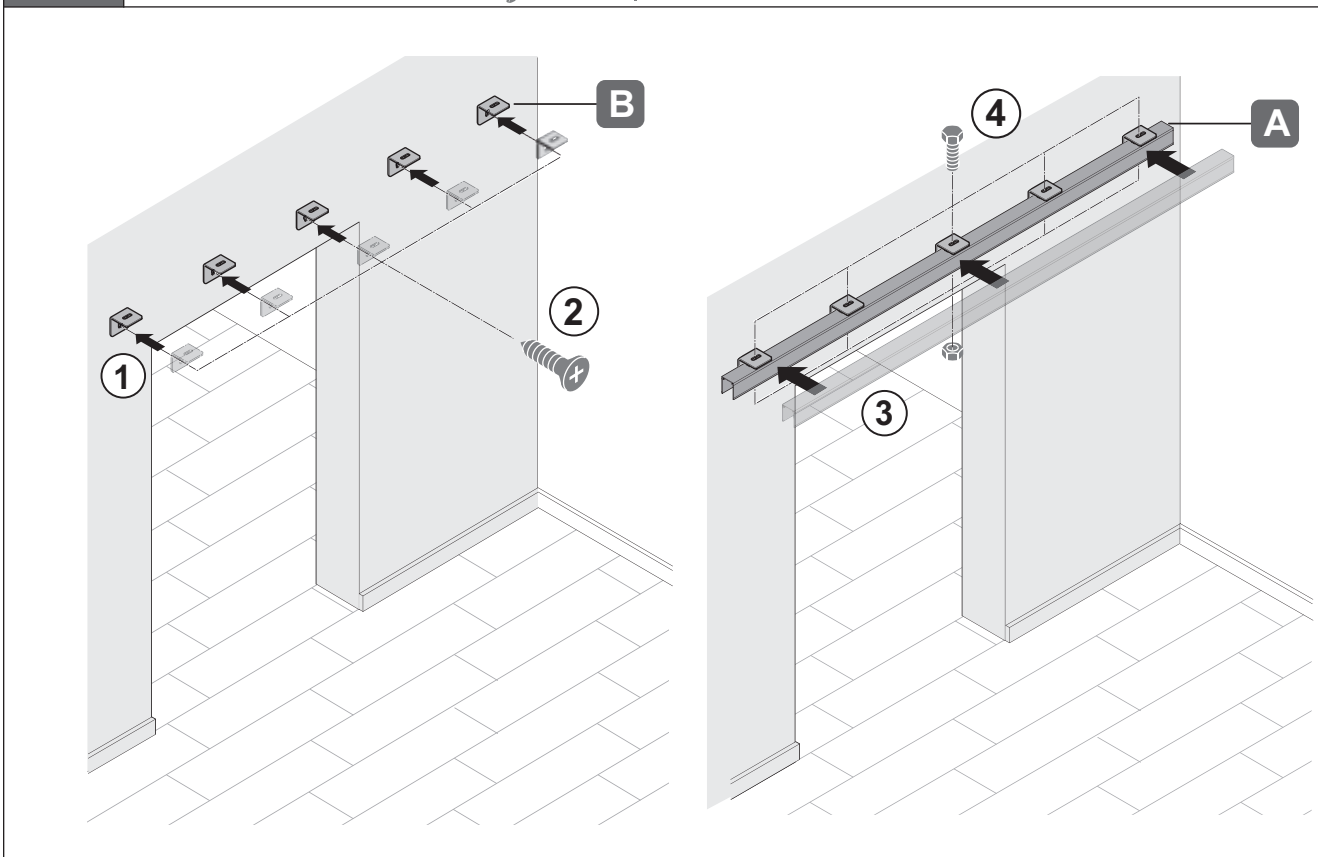

4

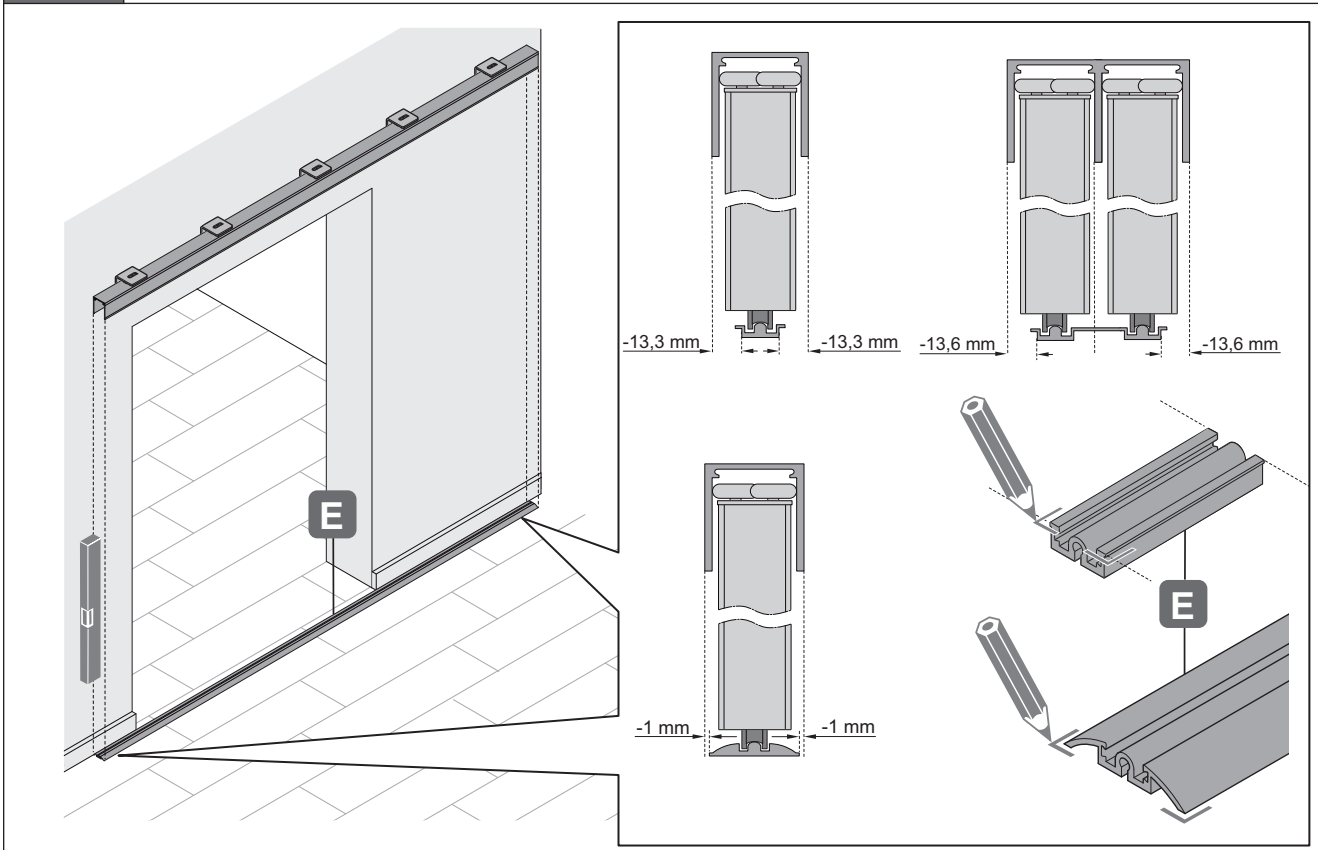
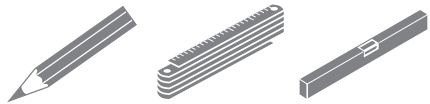

H 09/08 Maße in mm – Dimensions in mm – Medidas en mm



5

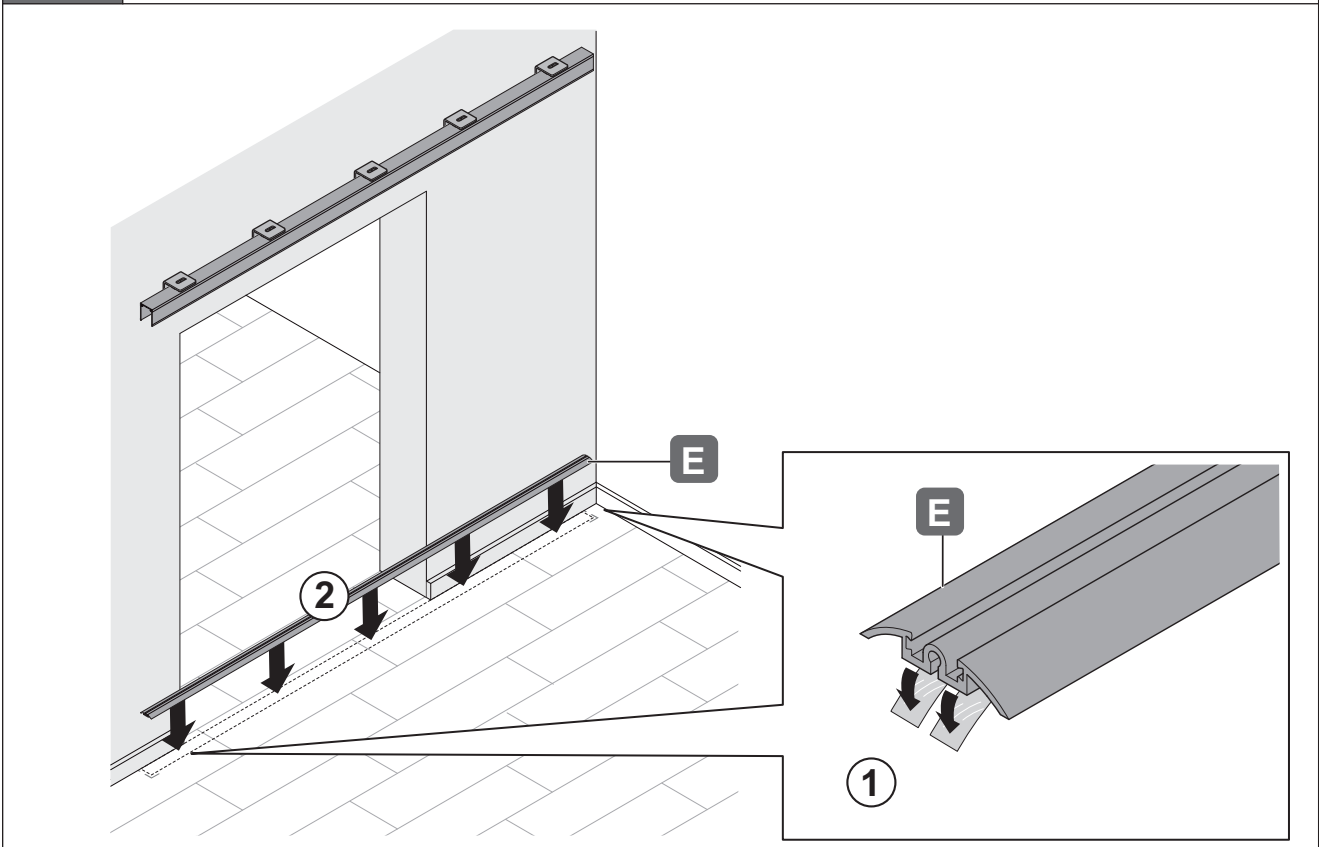

6

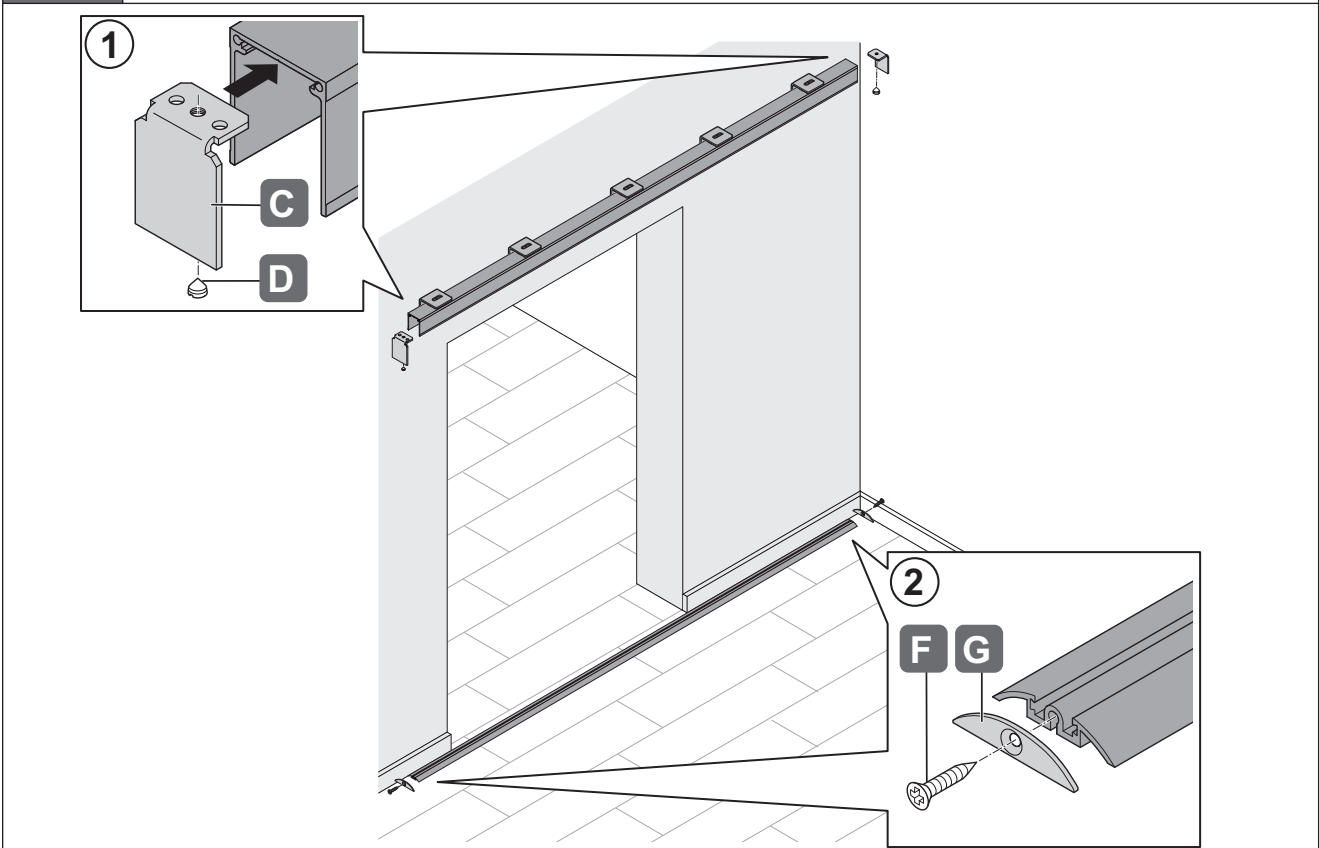

Infront - Montage Führungs- und Laufschienen
Infront - Guide and running track installation
Infront - Montage de rails de guidage et de roulement
Infront - Montaje de carriles guía y carriles de deslizamiento

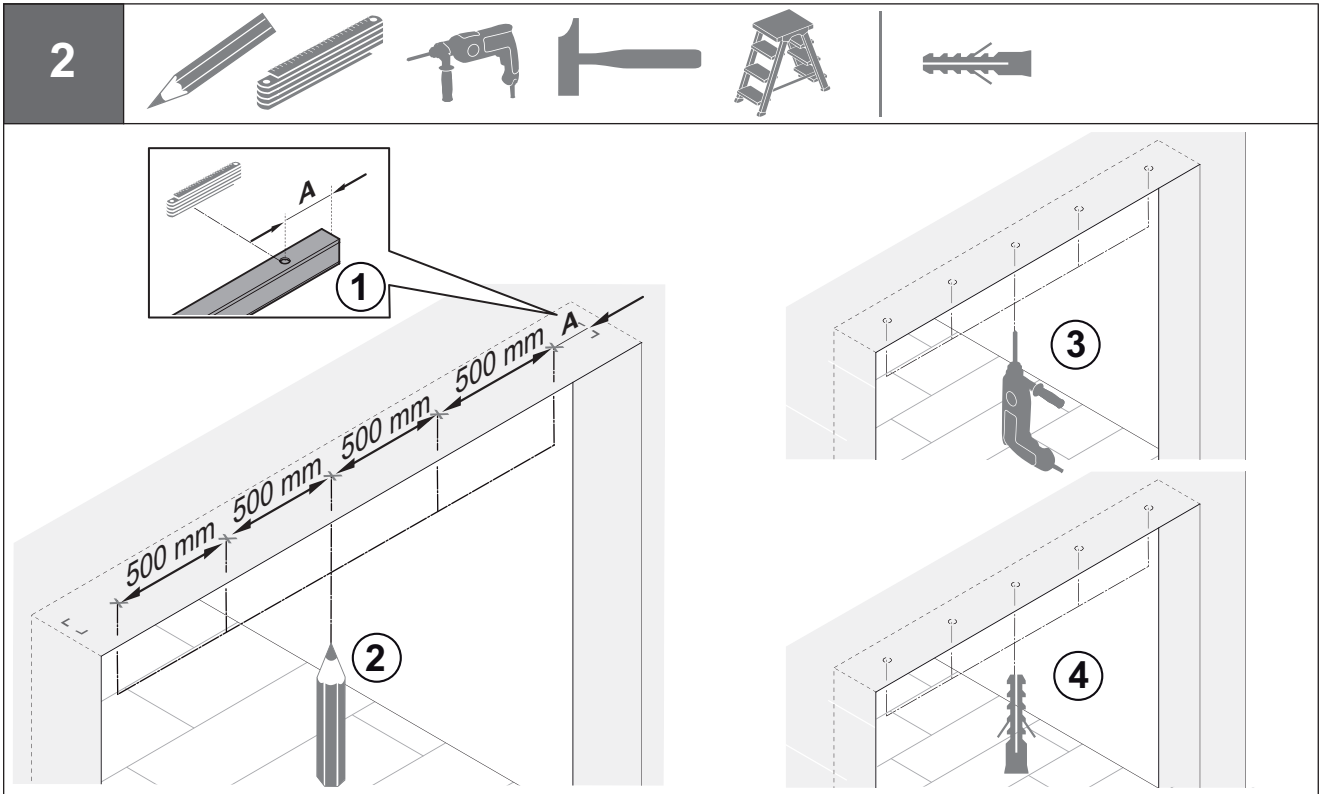
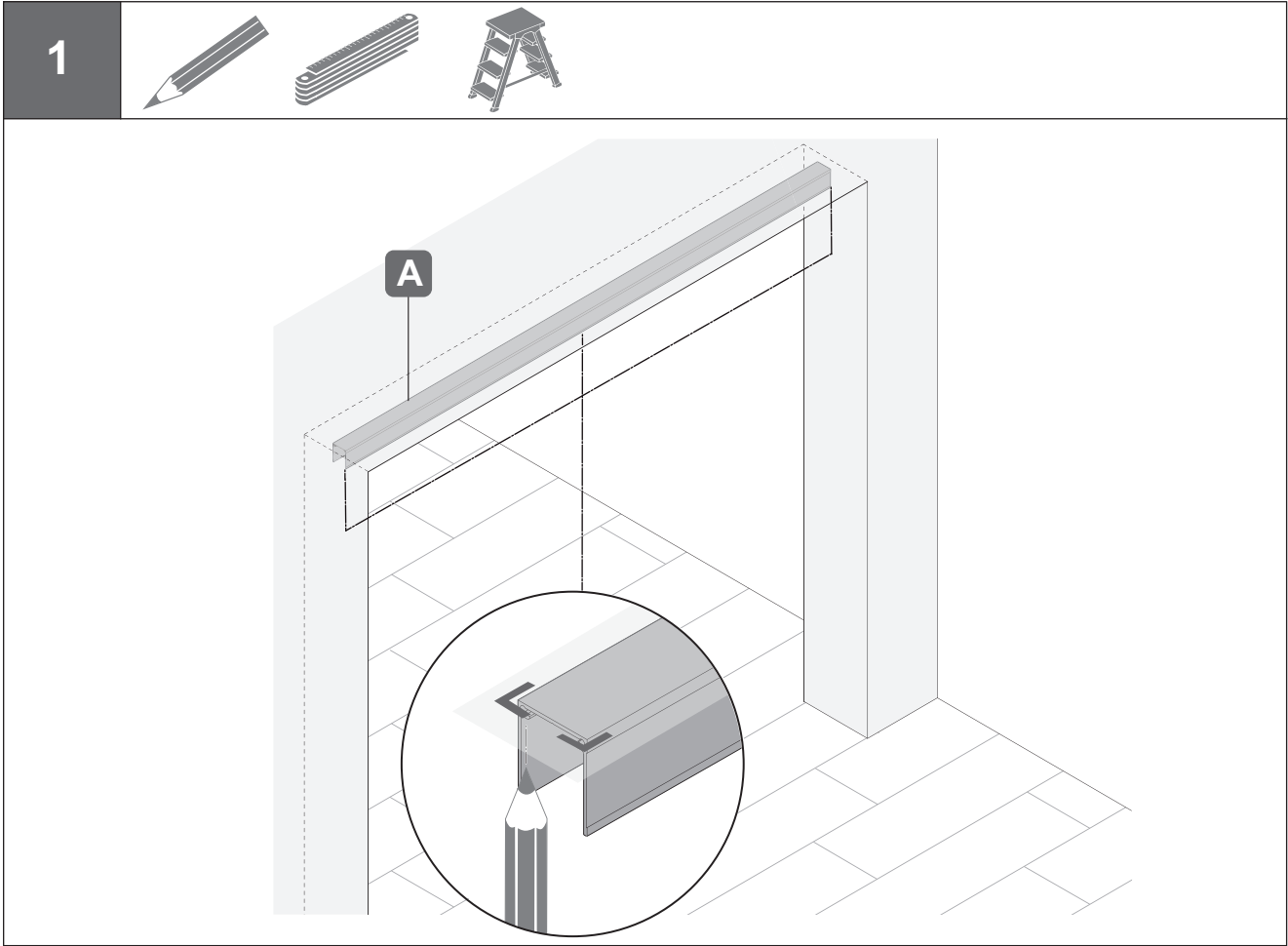

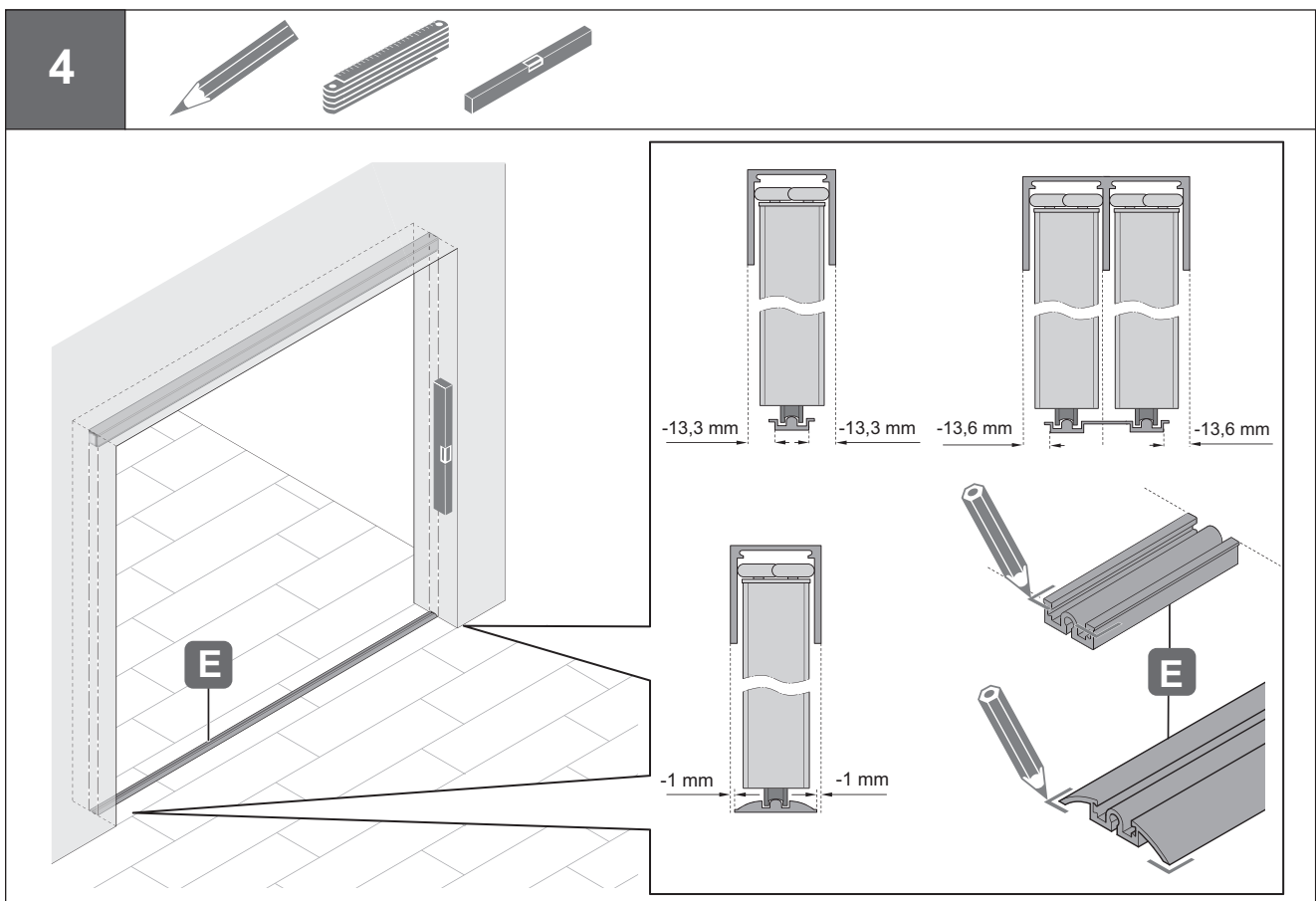
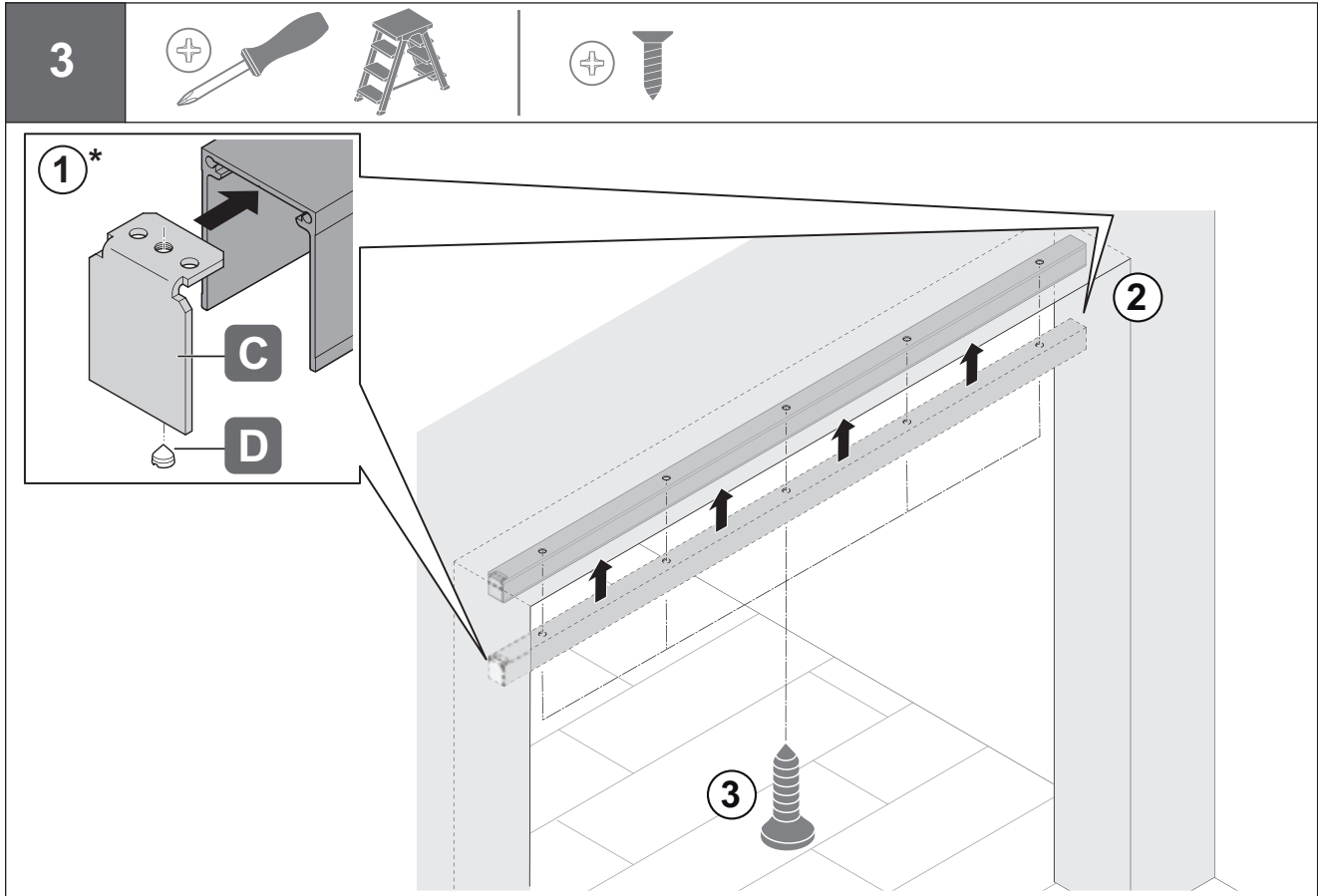

H 09/08 Maße in mm – Dimensions in mm – Medidas en mm

- *nur als Anschlag notwendig, wenn Dämpfung frei platziert wird
- * end stop only required if the soft closing mechanism is positioned freely
- * nécessaire en tant que butée uniquement lorsque l'amortissement est en placement libre
- * sólo es necesario como tope cuando la amortiguación se coloca en otra posición

5

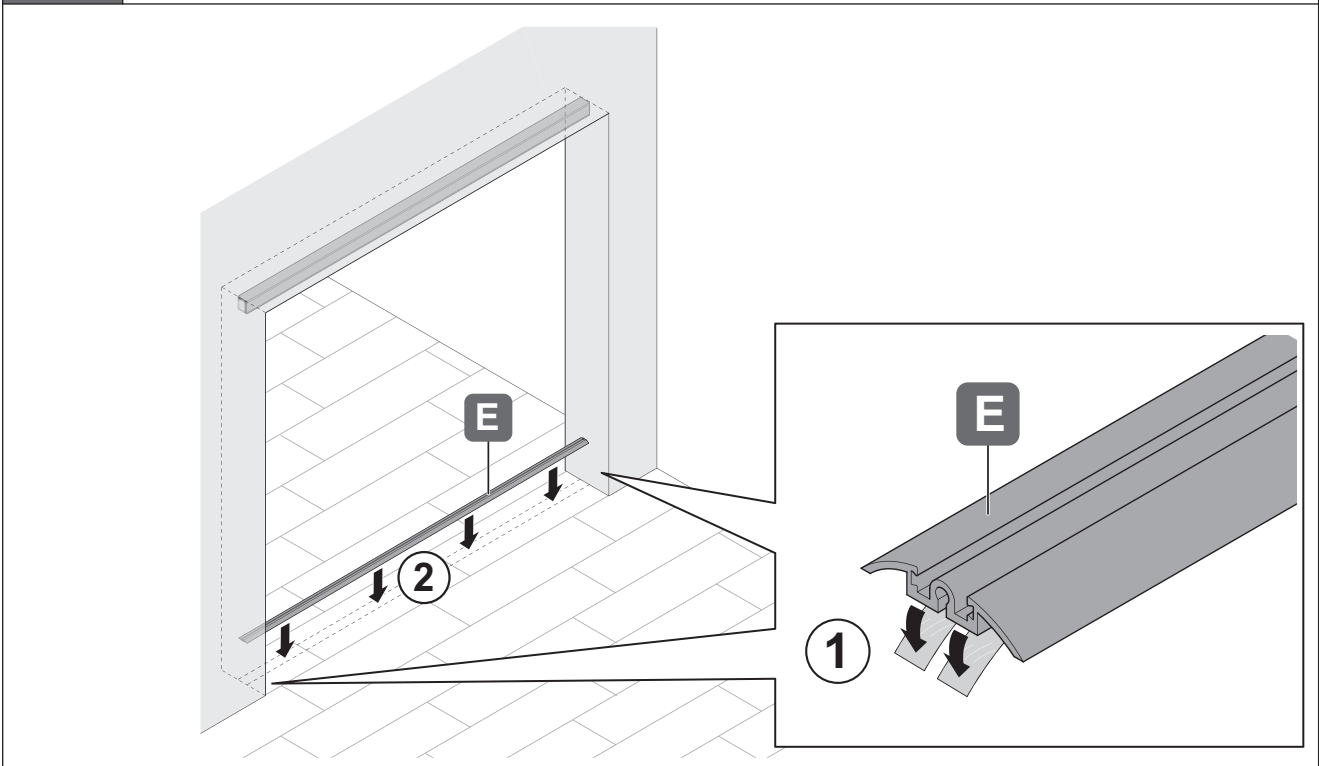



Schrägtürführung - Montage Führungs- und Laufschiene
Angled door guidance - Guide and running track installation
Guidage de porte avec inclinaison - Montage de rails de guidage et de roulement
Guía para puerta oblicua - Montaje de carriles guía y de deslizamiento

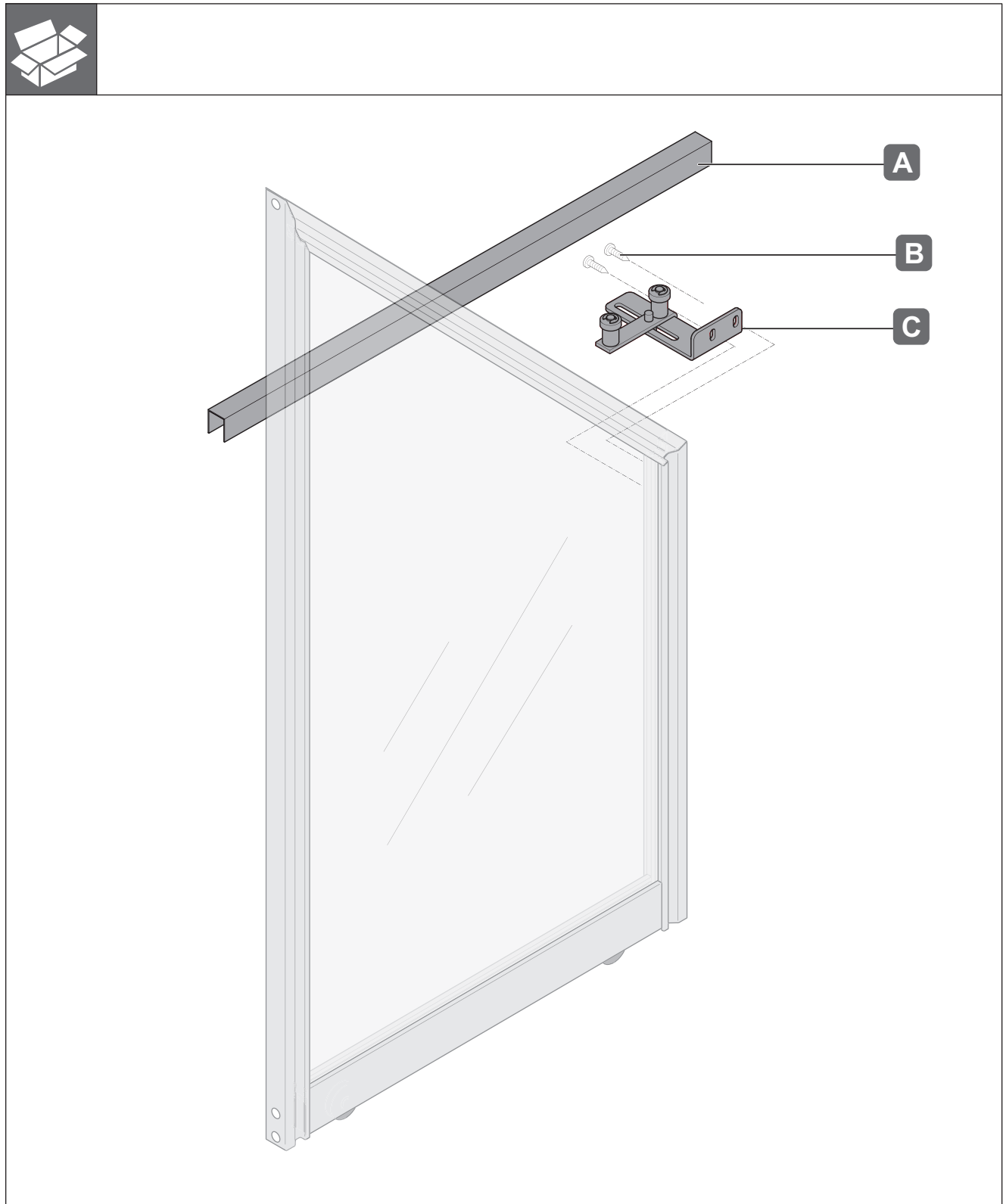
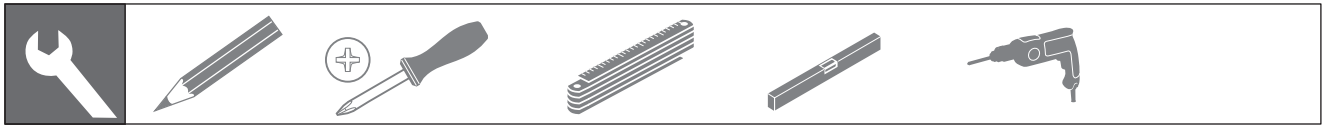



1

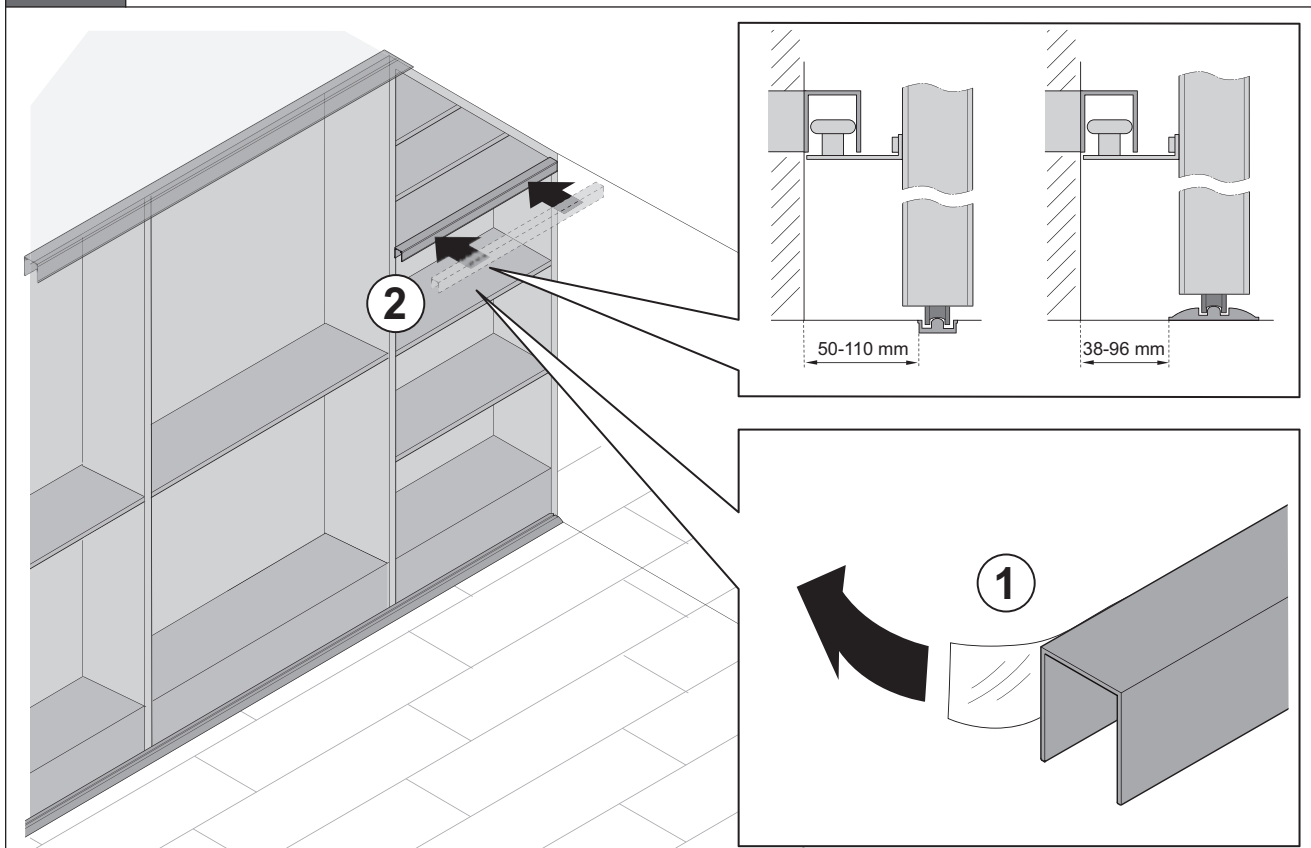
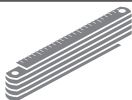

2

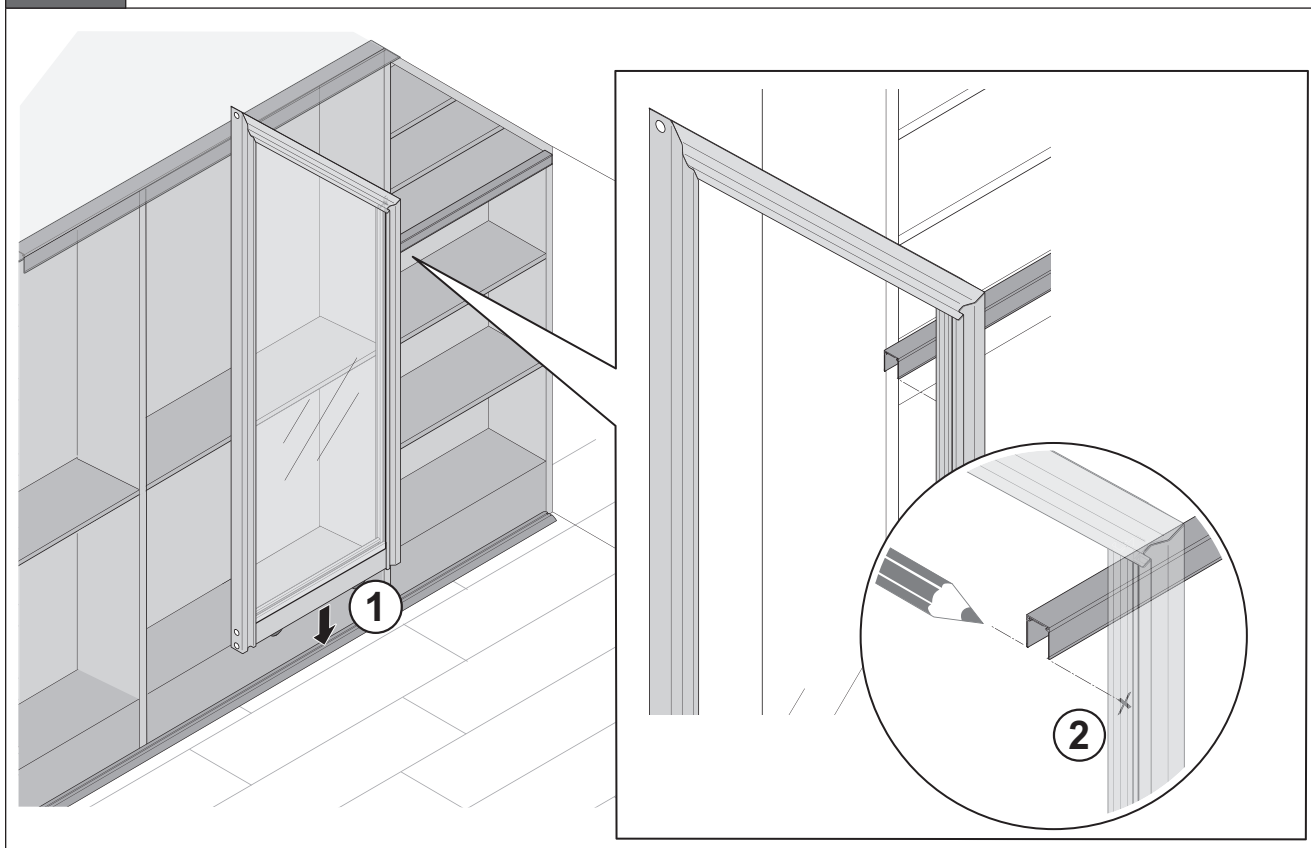
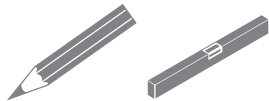

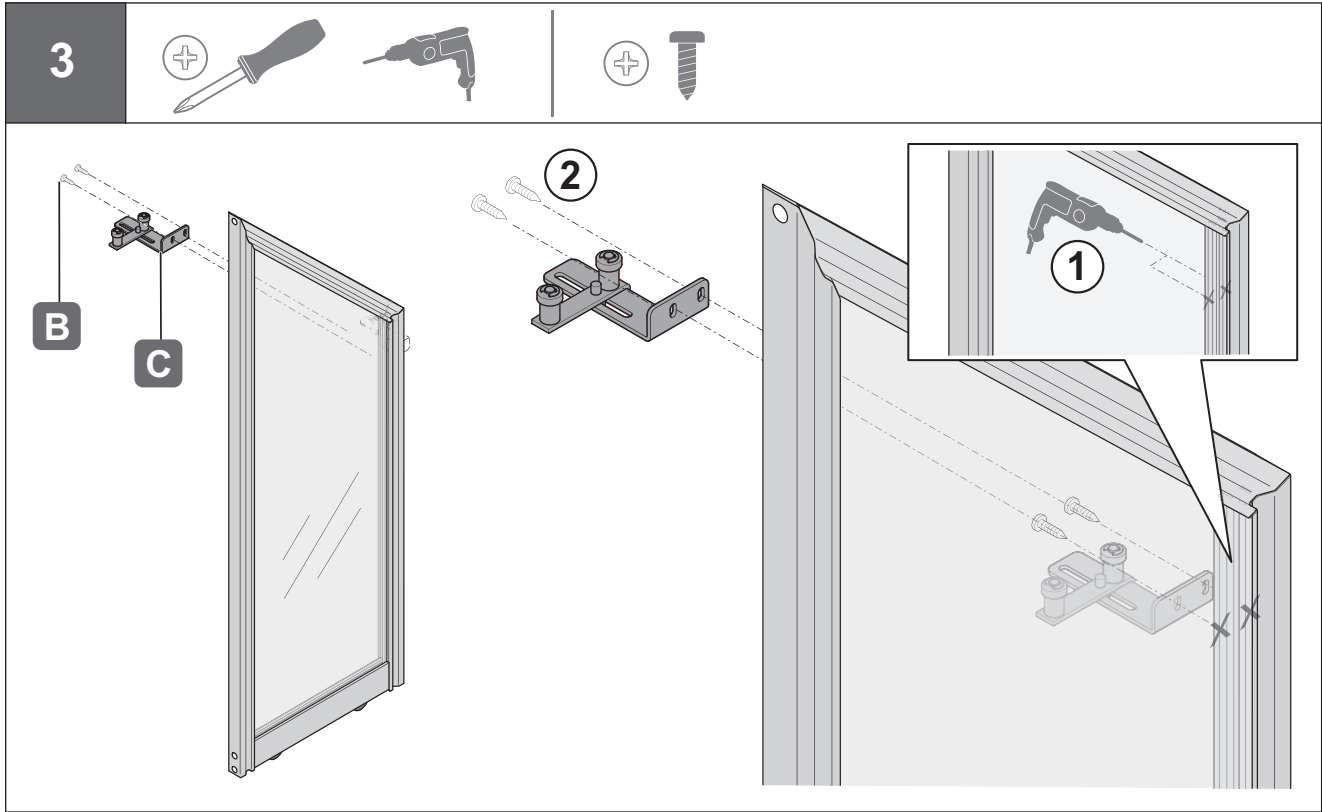



Tür ein/aushängen
Installing/removing door
Accrocher/décrocher la porte
Colgar / Descolgar la puerta

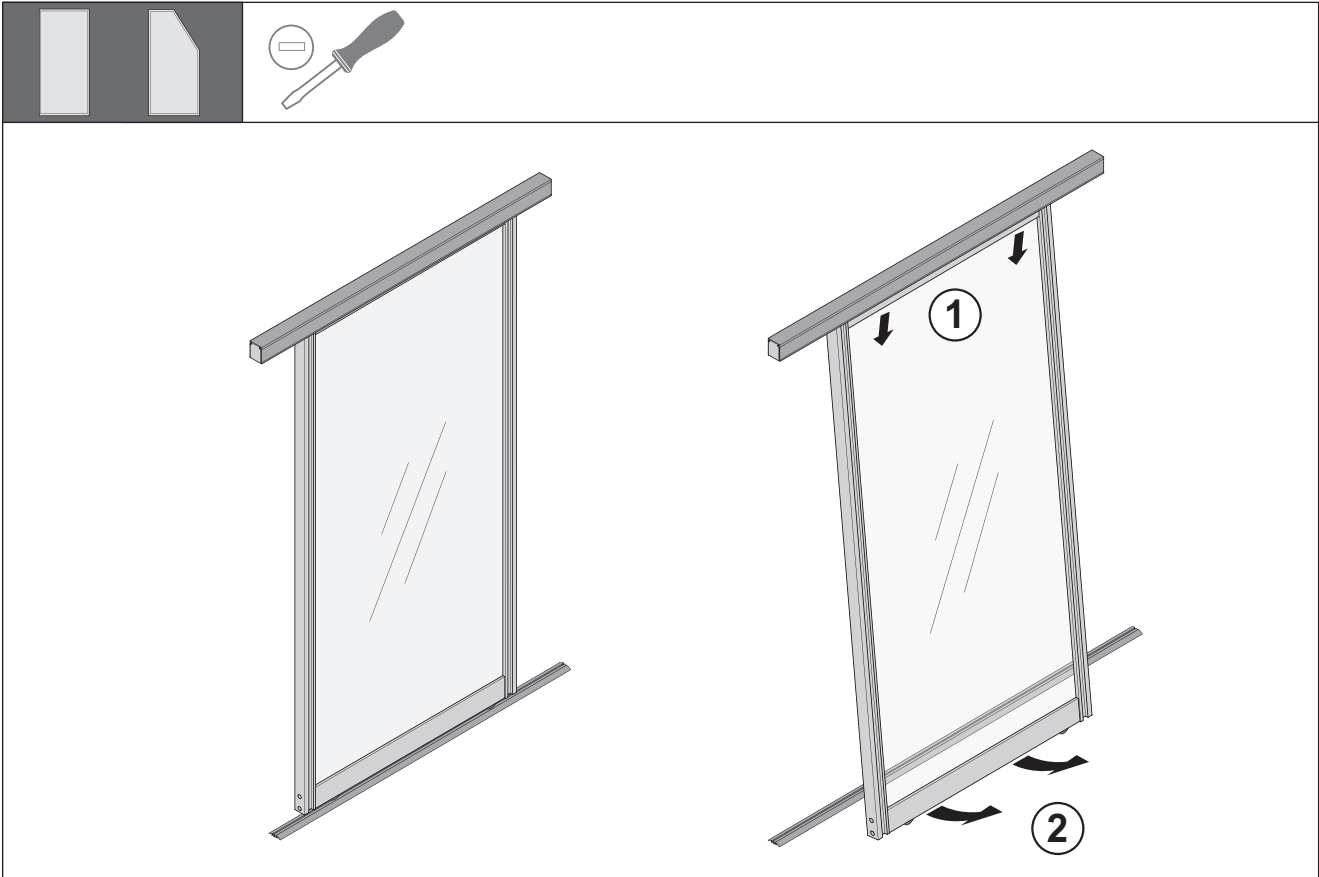
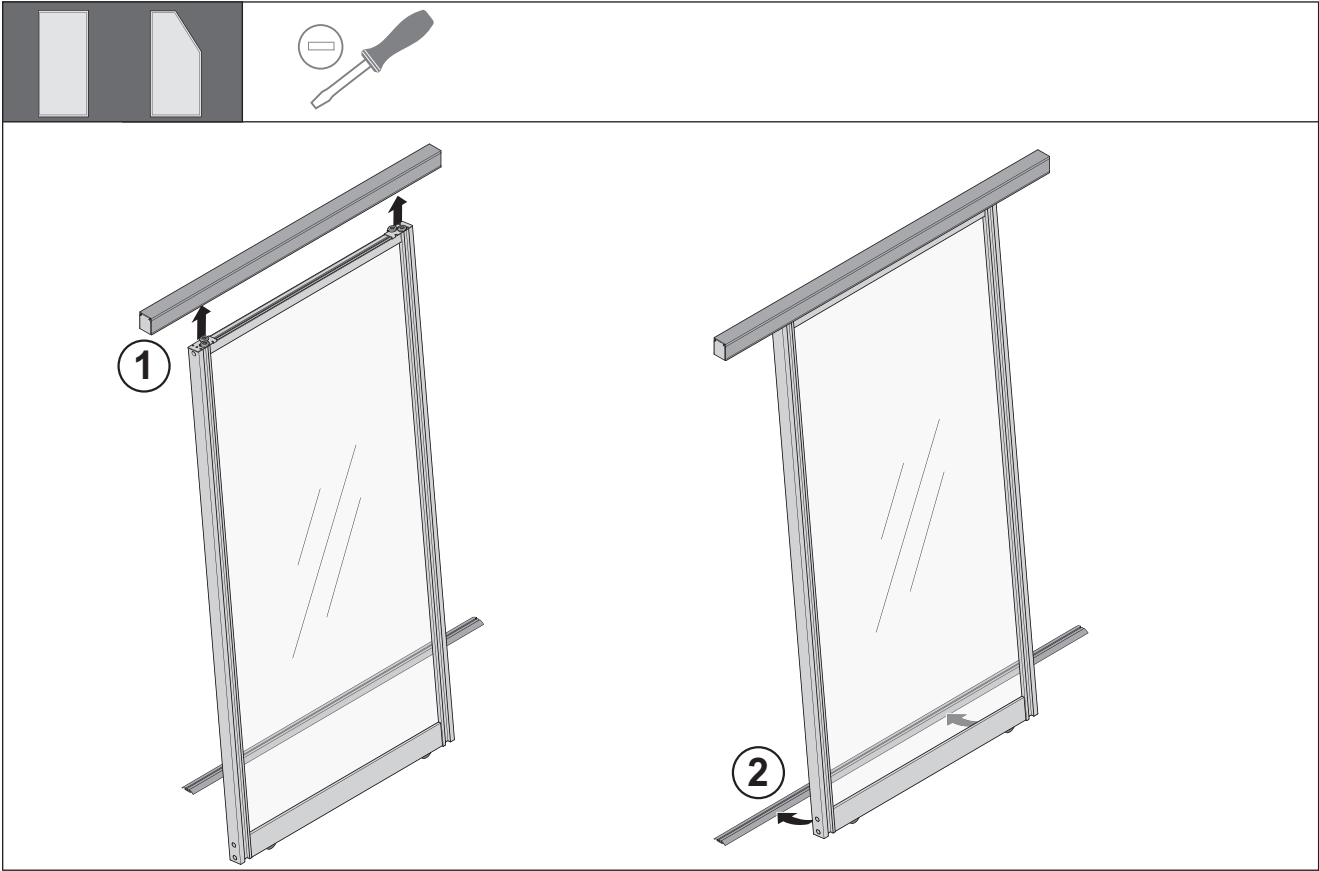

H 09/08 Maße in mm – Dimensions in mm – Medidas en mm

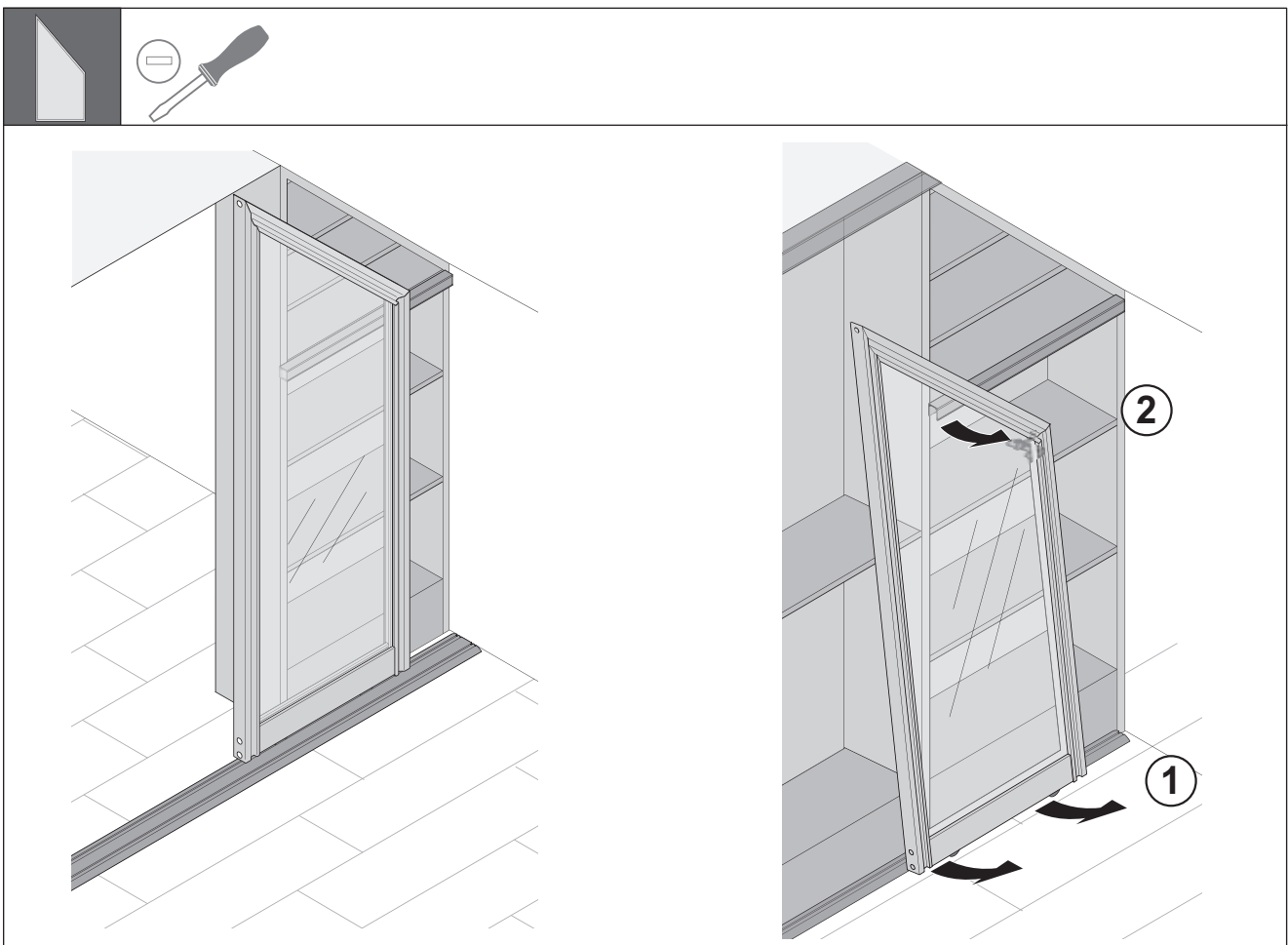
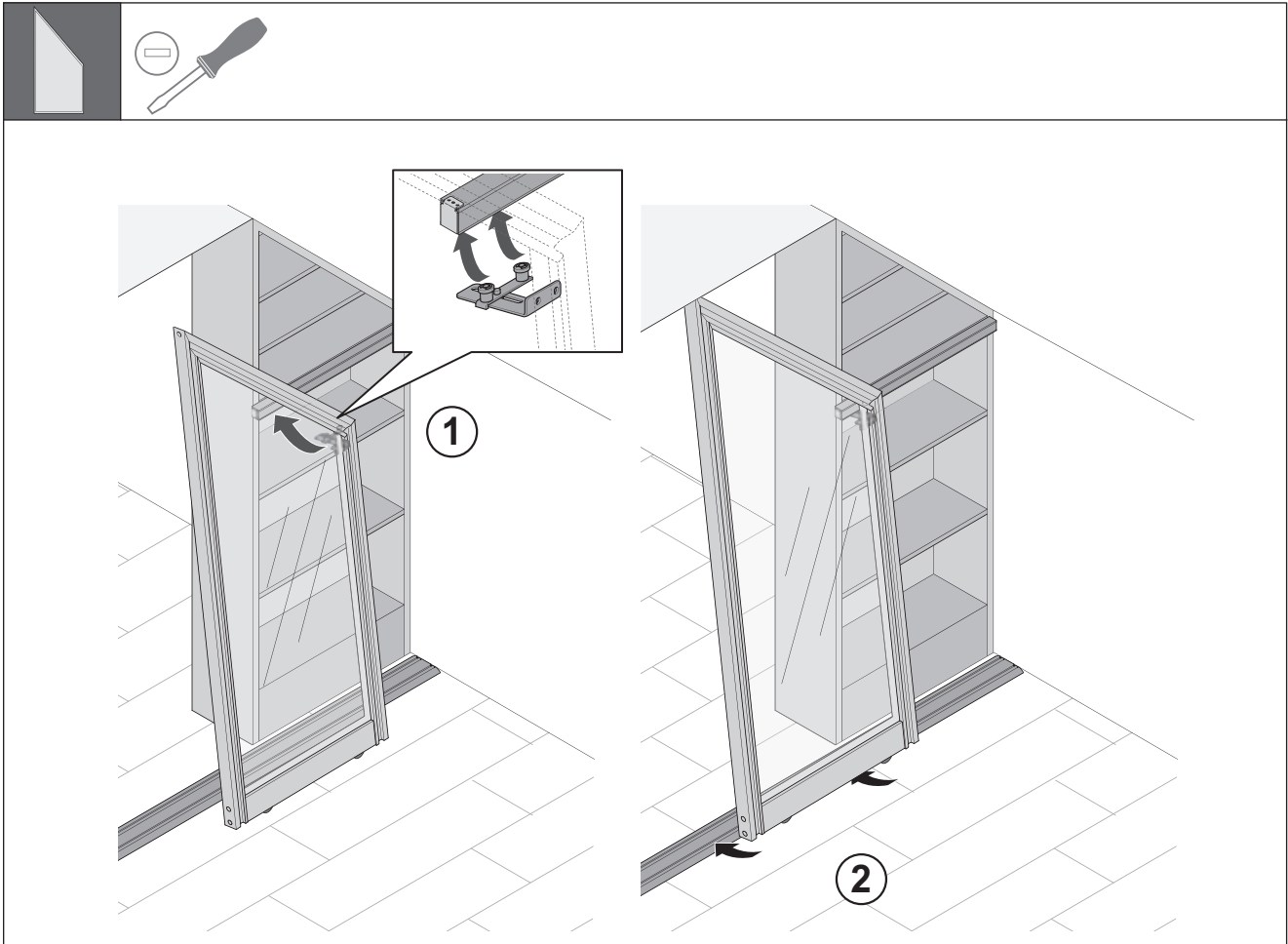



Einstellung
Adjustment
Réglage
Ajuste

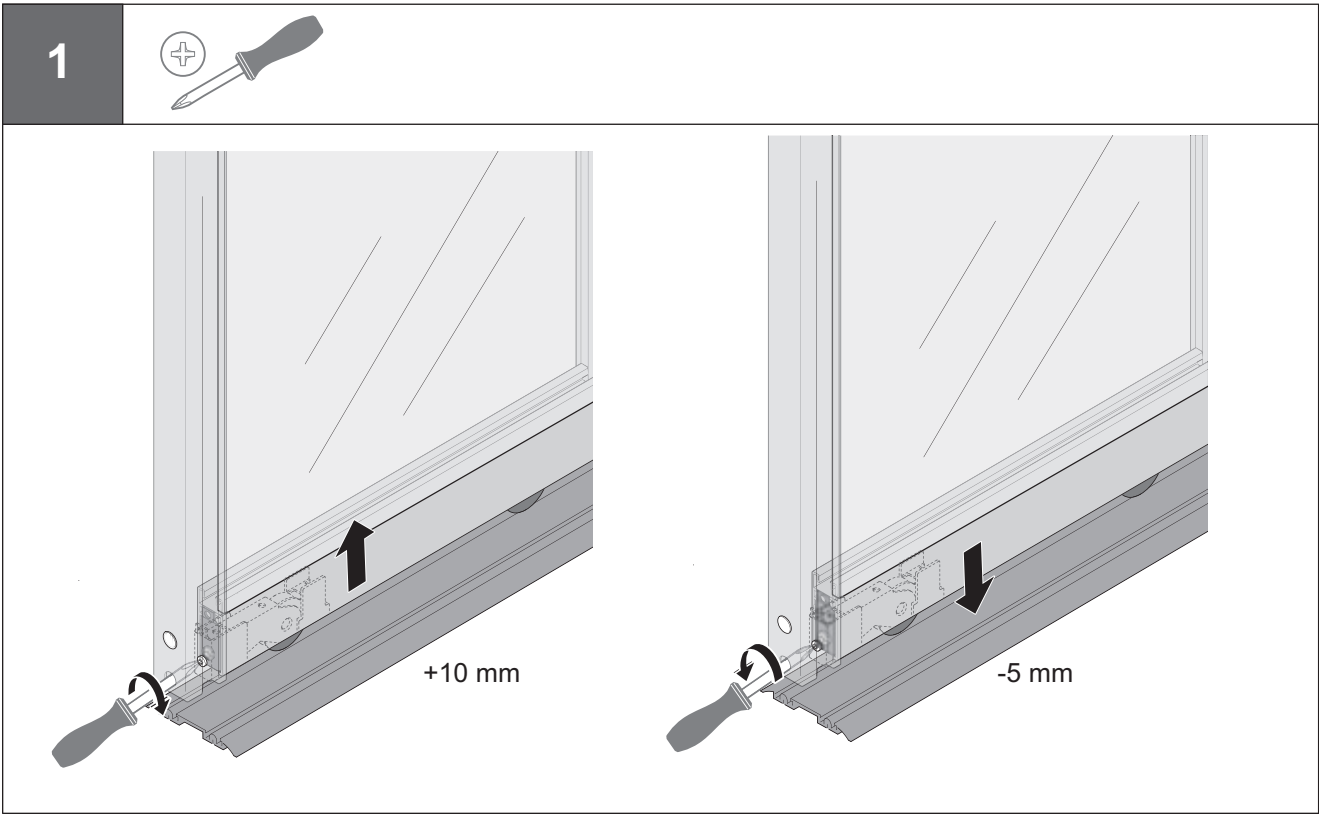

Zubehör
Accessories
Accessoires
Accesorios

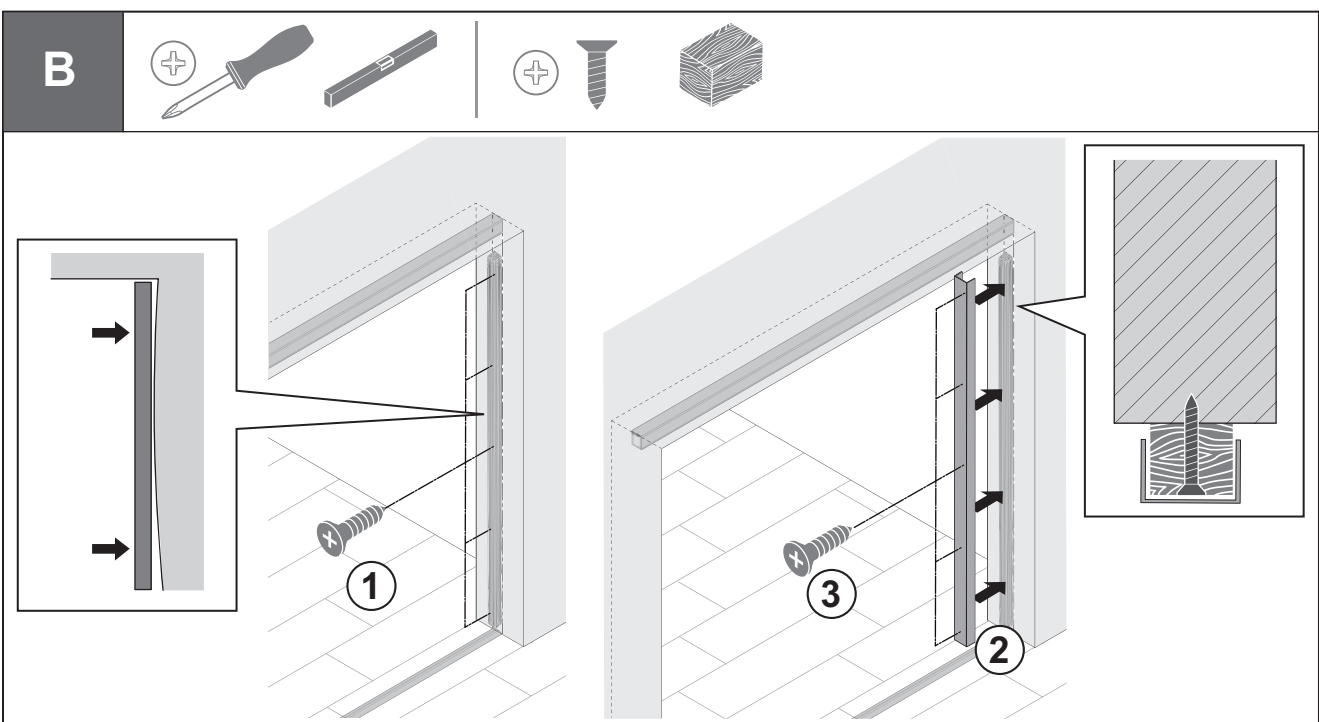
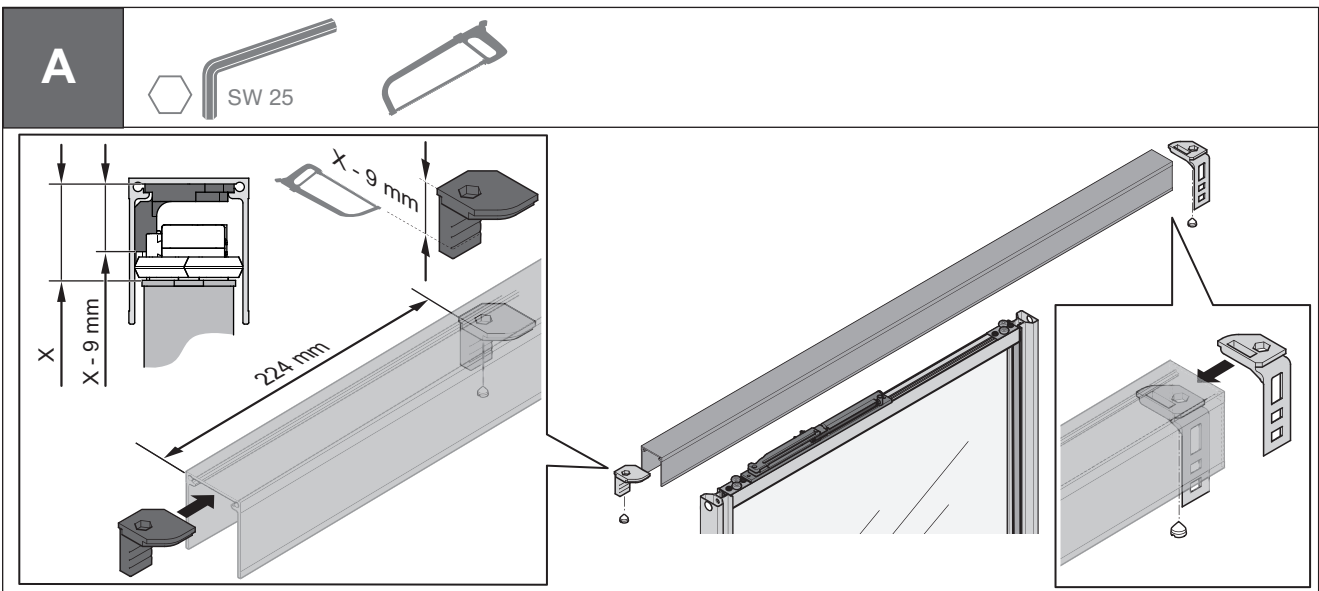
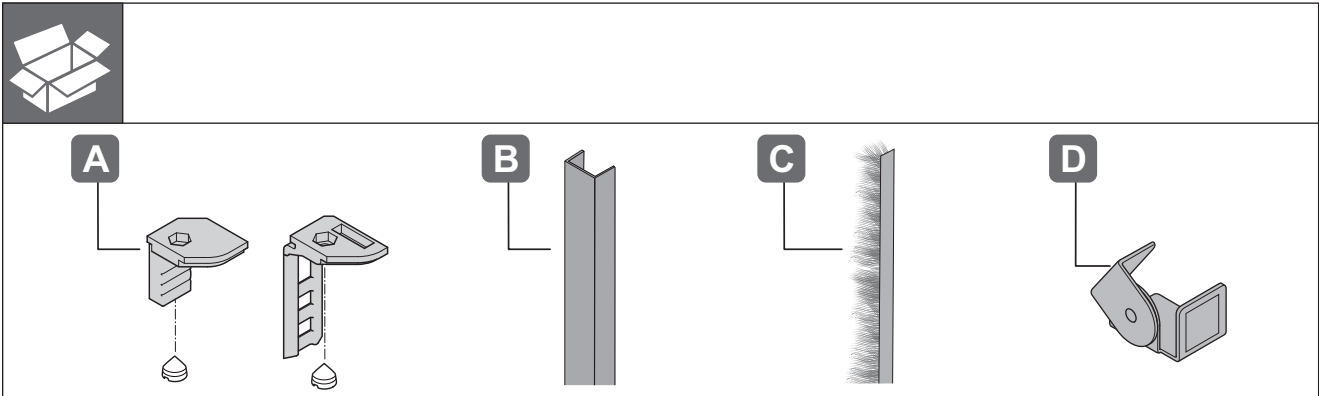

H 09/08 Maße in mm – Dimensions in mm – Medidas en mm

C

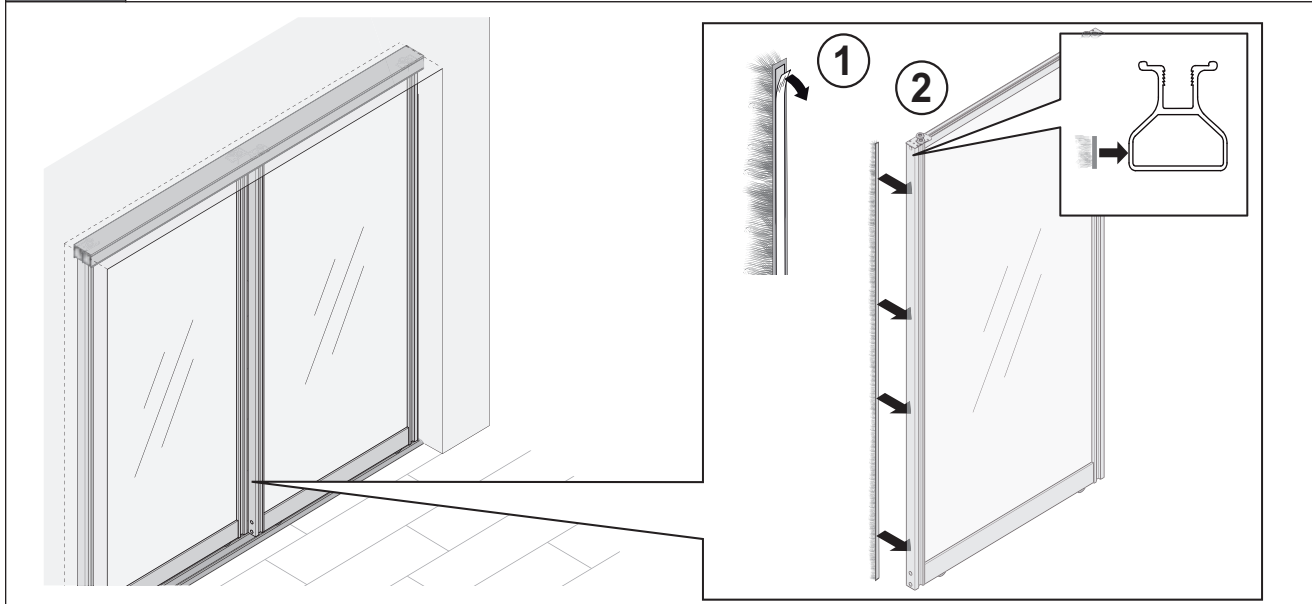

D

