





Slido

gilt für Artikel: siehe Tabelle
 applies to Cat. No.: see table
 valable pour référence : voir table
 adecuado para N° de ref.: ver table

| Classic | | Variante A Version A Versión A | Variante E Version E Versión E |
|---------|------|--------------------------------------|--------------------------------------|
| 40-F | Holz | | 940.67.008 |
| 50-F | Holz | 940.67.000 | 940.67.004 |

i



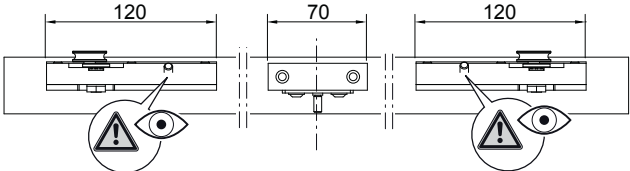

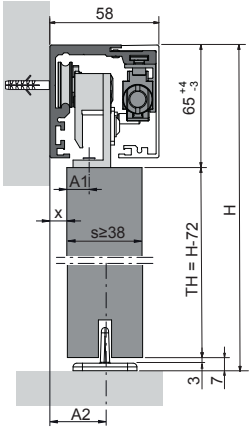
H = Gesamthöhe TH = Türhöhe

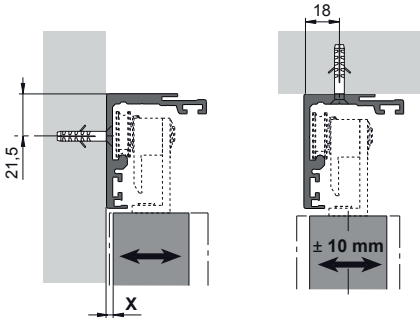

s = 40

| X mm | A1 mm | A2 mm |
|------|-------|-------|
| 3 | 17,5 | 23 |
| 4 | 16,5 | 24 |
| 5 | 15,5 | 25 |
| 6 | 14,5 | 26 |
| 7 | 13,5 | 27 |
| 8 | 12,5 | 28 |

i

**Variante A
Version A
Versión A**

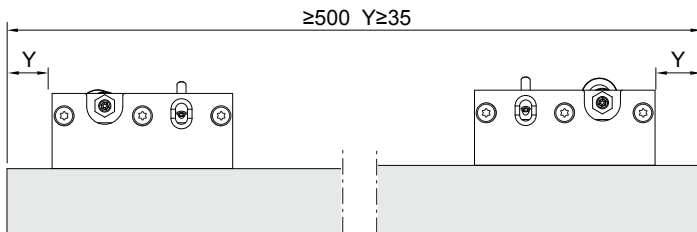

i

**Variante E
Version E
Versión E**

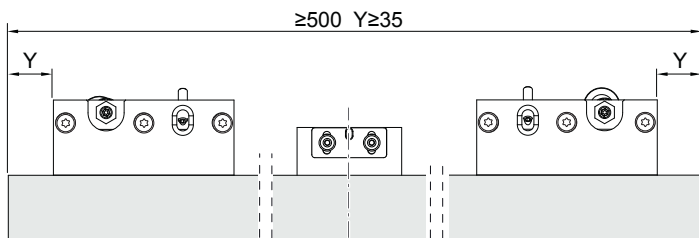

i

**Variante A
Version A
Versión A**

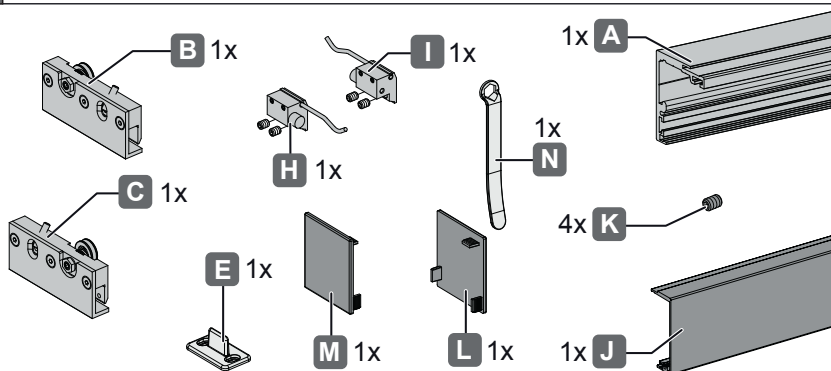

i

Variante E
Version E
Versión E

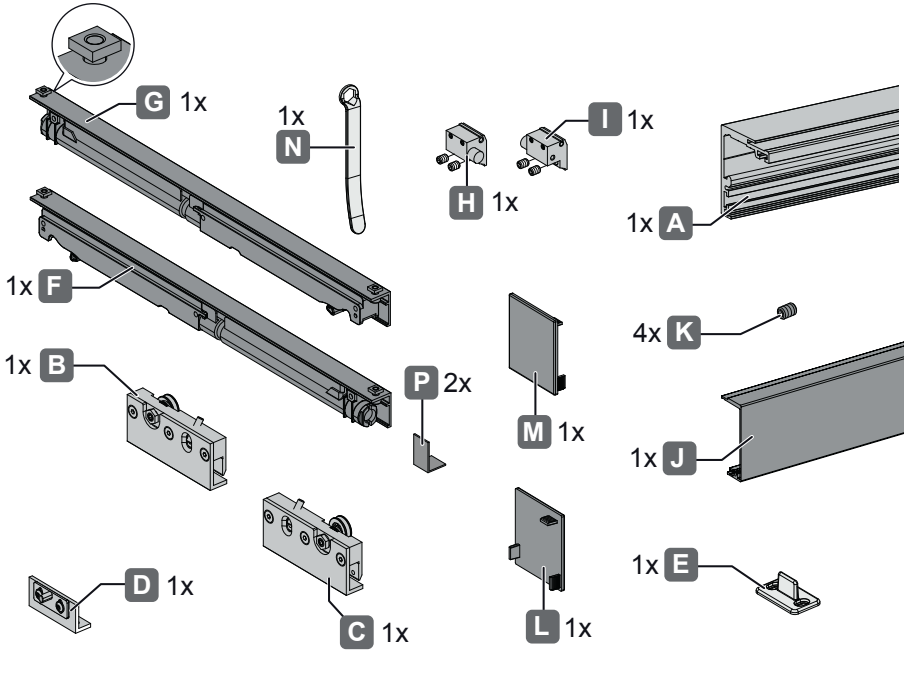

+

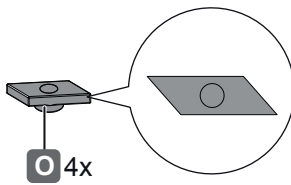

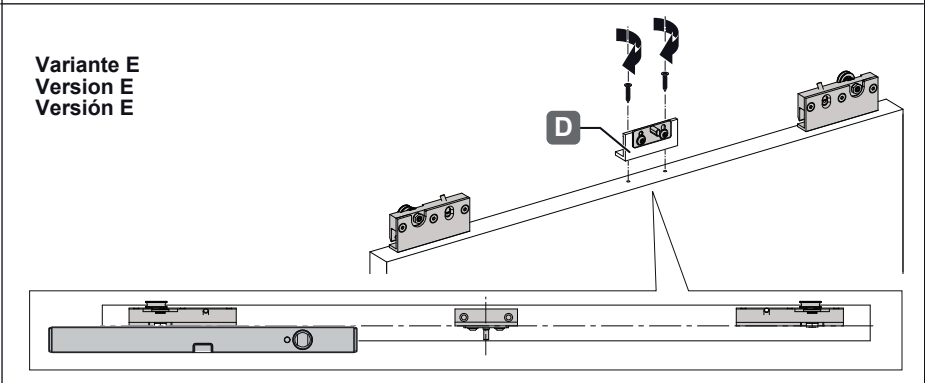
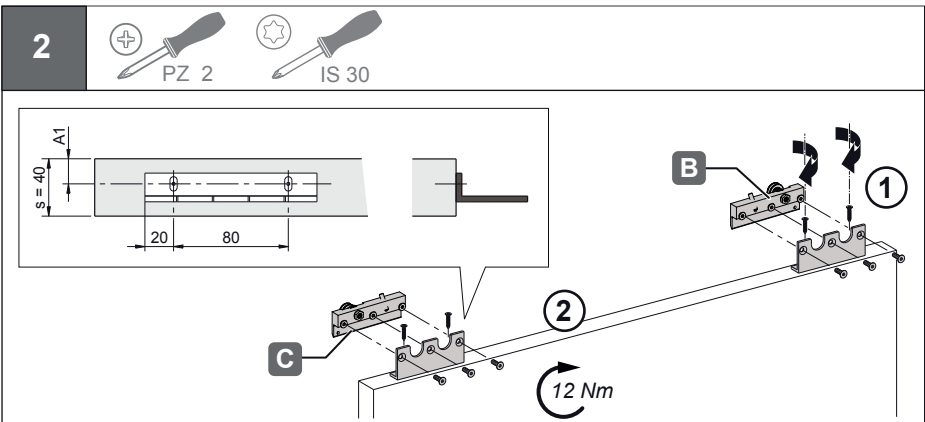
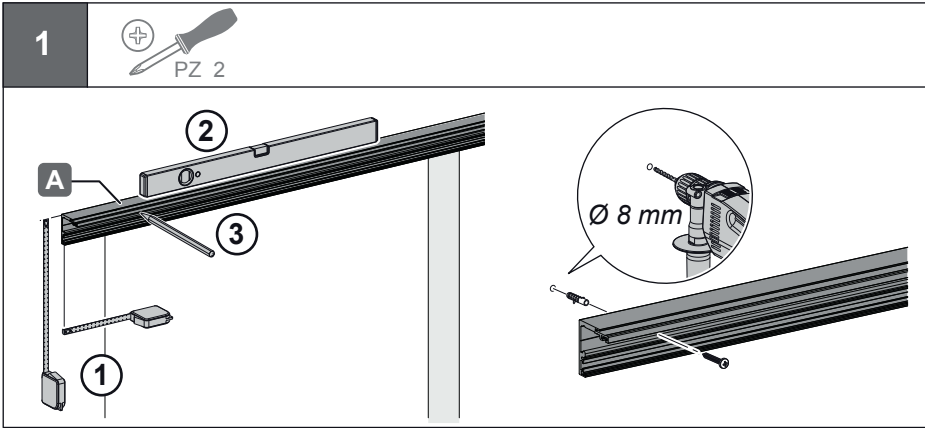

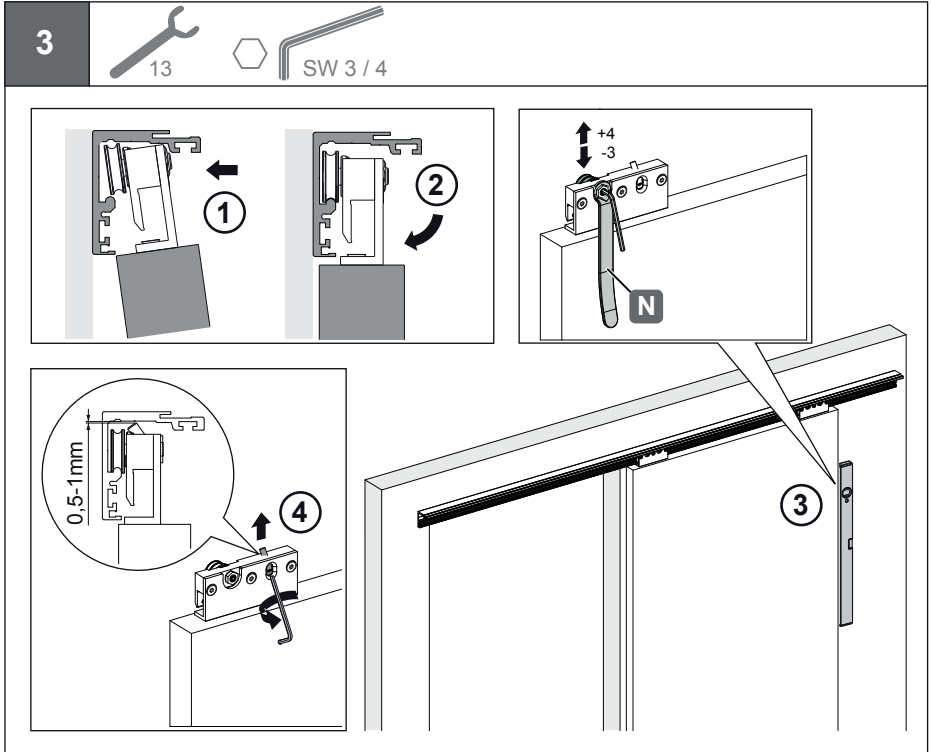

4



A

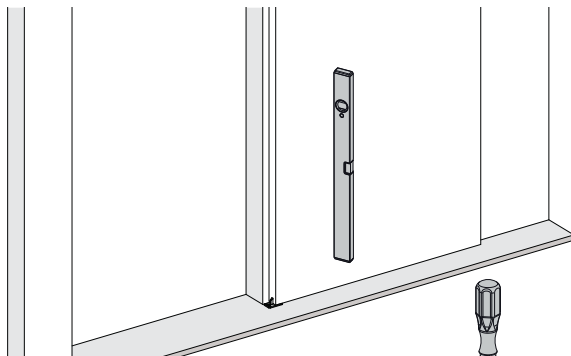

B

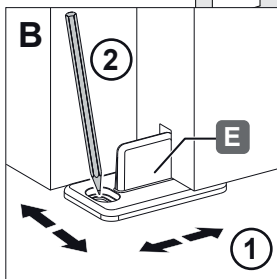

C

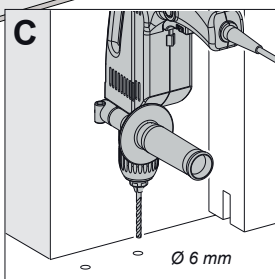

D

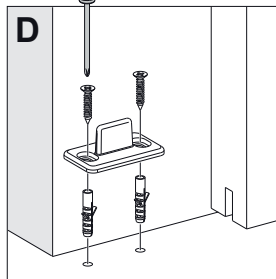

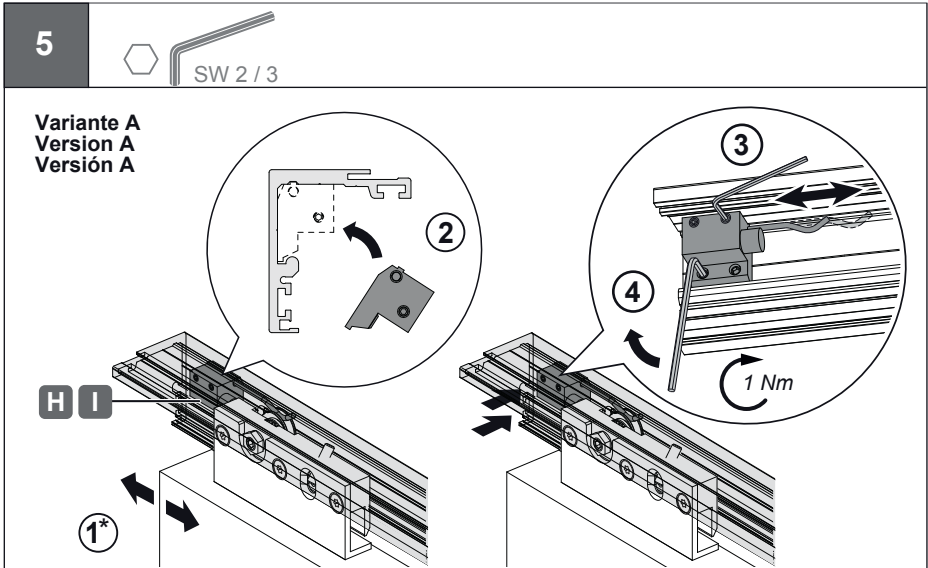

1* Tür in gewünschte Endposition schieben.

1* Slide door into the required end position.

1* Pousser la porte coulissante dans la position finale souhaitée.

1* Empujar la puerta corrediza en la posición final deseada.

5



SW 3

Variante E
Version E
Versión E

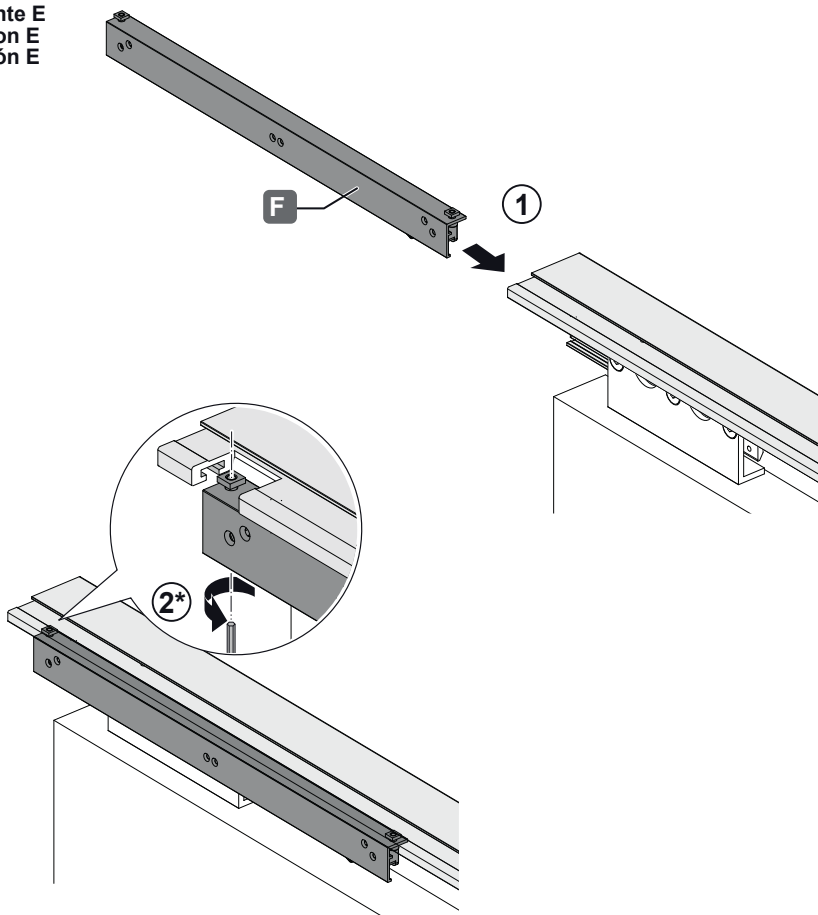

2* Nur leicht anziehen, der Dämpfer muss noch beweglich bleiben!

2* Only lightly tighten, the damper must still remain mobile!

2* Seulement serrer légèrement, l'amortisseur doit continuer d'avancer!

2* Sólo apriete ligeramente, el amortiguador tiene que mantenerse en movimiento!

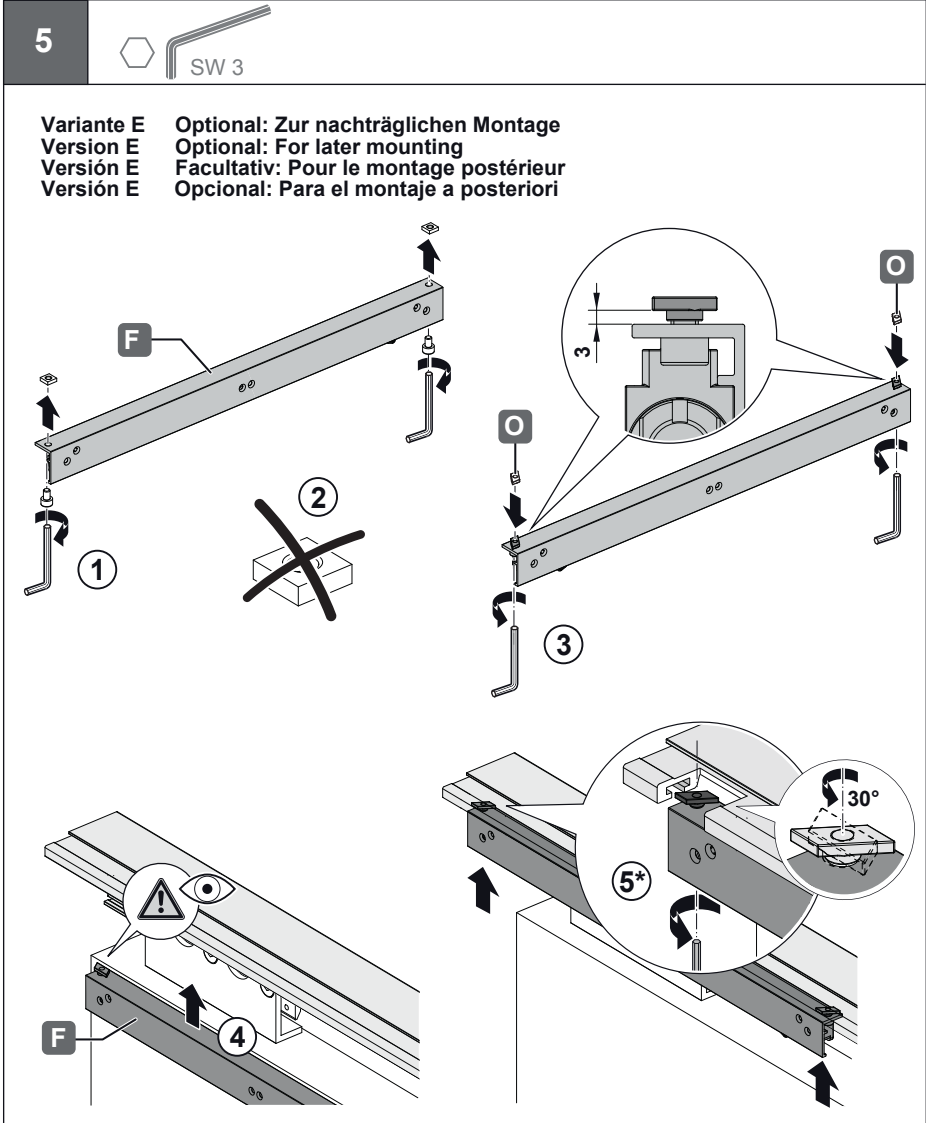

HDE 30.09.2016

5* Nur leicht anziehen, der Dämpfer muss noch beweglich bleiben!

5* Only lightly tighten, the damper must still remain mobile!

5* Seulement serrer légèrement, l'amortisseur doit continuer d'avancer!

5* Sólo apriete ligeramente, el amortiguador tiene que mantenerse en movimiento!

5



Variante E
Version E
Versión E

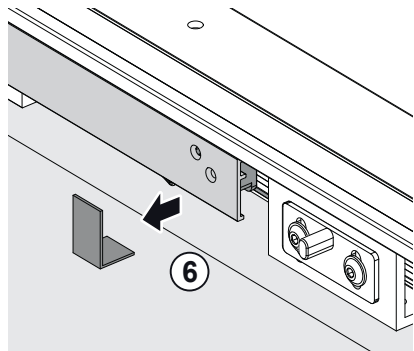
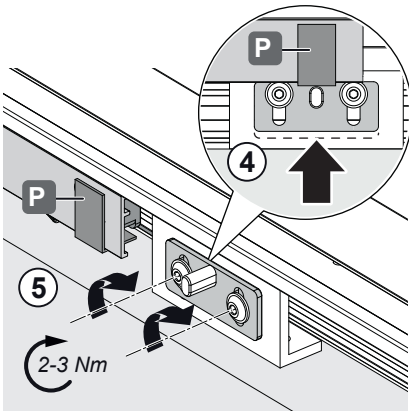
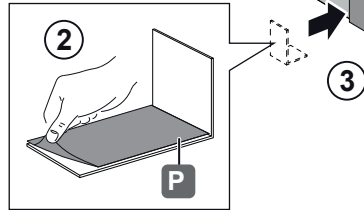
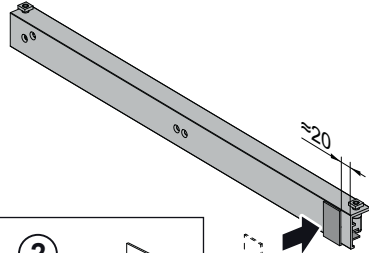
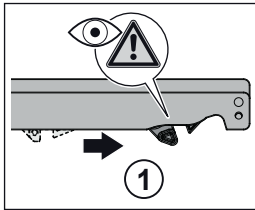
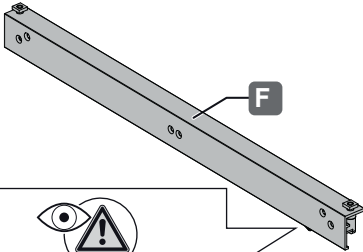

5
2-3 Nm

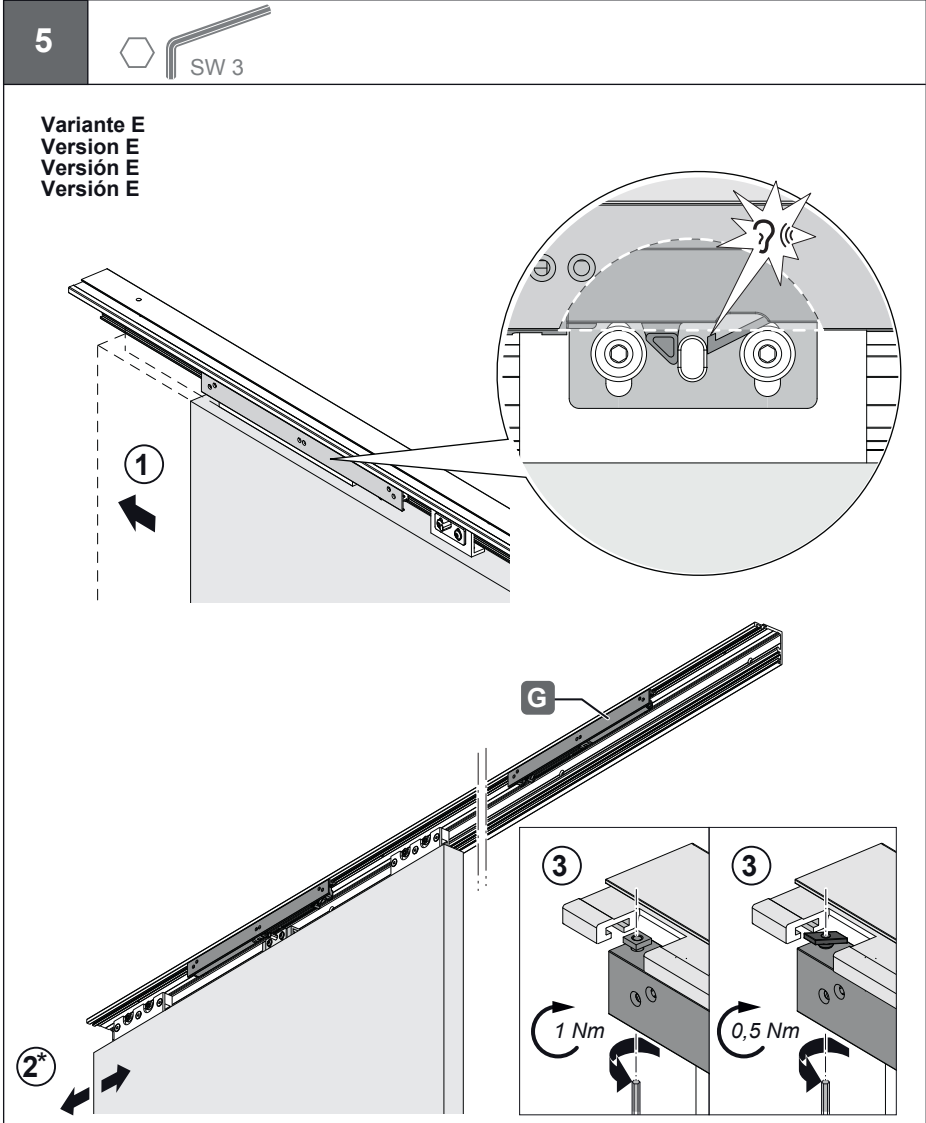

HDE 30.09.2016

2* Tür und Dämpfer in gewünschte Endposition schieben.

2* Slide door and damping into the required end position.

2* Pousser la porte et à amortissement coulissante dans la position finale souhaitée.

2* Empujar la puerta y amortiguación corrediza en la posición final deseada.

5



Variante E
Version E
Versión E

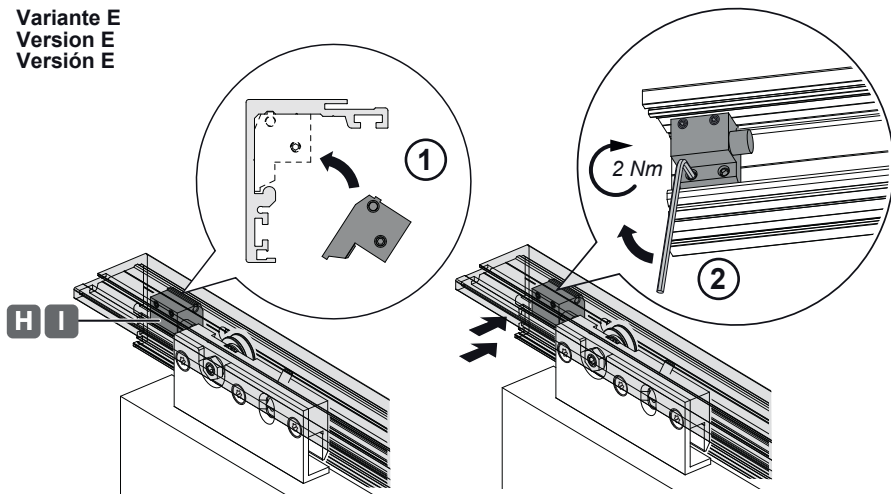

Alle Schraubenverbindungen auf festen Sitz überprüfen und ggf. nachziehen!
 Check all screw connections for firm seating and retighten if necessary!
 Vérifier la solidité de tous les vissages, les resserrer si nécessaire!
 Verificar que todos los tornillos estén en el lugar correcto, llegado el caso, apretarlos!

6

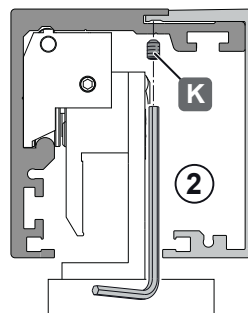
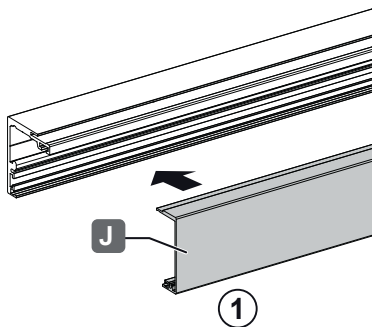

7

